

Microblasting Equipment

PEENMATIC 750S

Hinged Front Charging Door



- Standard equipment:**
- Service door, swivelling, with integrated sight window, provided with a safety glass and an attrition-proof glass in a quick change frame
 - Hinged front charging door, width 710 x height 280 mm
 - Door interruption switch
 - Working grate made of perforated plate, two-piece, detachable, diameter of holes 5 mm
 - Padded sleeves and gloves, exchangeable
 - Microblasting pistol unit, type EF 3, with hard metal blasting nozzle HSD 5/10, adjustable via pressure reducing valve, 0 - 8,5 bar, microblasting pressure reading on the manometer
 - Holding device for microblasting pistol with swinging arm, height 115 mm, swivelling range 275 mm
 - Microblasting agent pre-accelerating system with moving injector, adjustable via pressure reduction valve, 0 - 4 bar, pressure reading on the manometer
 - Automatic, selective microblasting agent recycling system, type SHOT SEPARATOR
 - Built-in high surface microfilter unit, including dust collector with cover and connection flexible tube
 - Ventilator for high surface microfilter unit, electronically continuously variable
 - Blow-out pistol (air-blasting pistol)
 - Foot actuated switch with impulse contact
 - Compressed-air connection, 1/4", at equipment, including oil and water separator
 - Control panel with all necessary switches and control elements
 - Key-operated switch, on / off, with 2 keys
 - Illumination, 2 x 18 W

- Accessories:**
(on request)
- Moveable structural aluminium rack, including tin plate
 - Built-in rotary table unit, made of aluminium, Ø 350 mm, manually rotatable, for workpieces up to a maximum of 50 kg
 - Continuous drying system for microblasting agents, electronically continuously adjustable with heating power control unit
 - Side feeding door(s), width 410 x height 220 mm, on the left and / or on the right side
 - Hour counter of microblasting time

Sales / Development
iepco ag
Hofstrasse 21
CH-8181 Höri
Phone +41 / (0)44 861 16 16
Fax +41 / (0)44 860 63 86
www.iepco.ch

Production Plant
iepco ag
Steiächerweg 10
CH-5316 Leuggern
Phone +41 / (0)56 268 80 40
Fax +41 / (0)56 268 80 50
info@iepco.ch

Technologies for
perfect surfaces

Microblasting Equipment PEENMATIC 750S

Hinged Front Charging Door

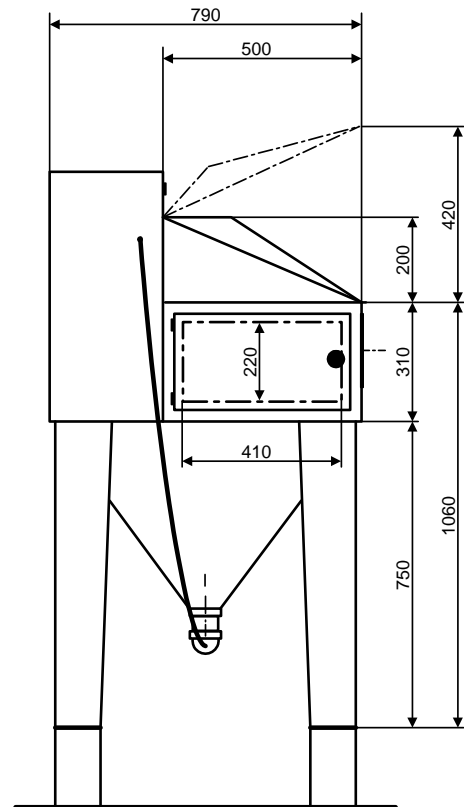
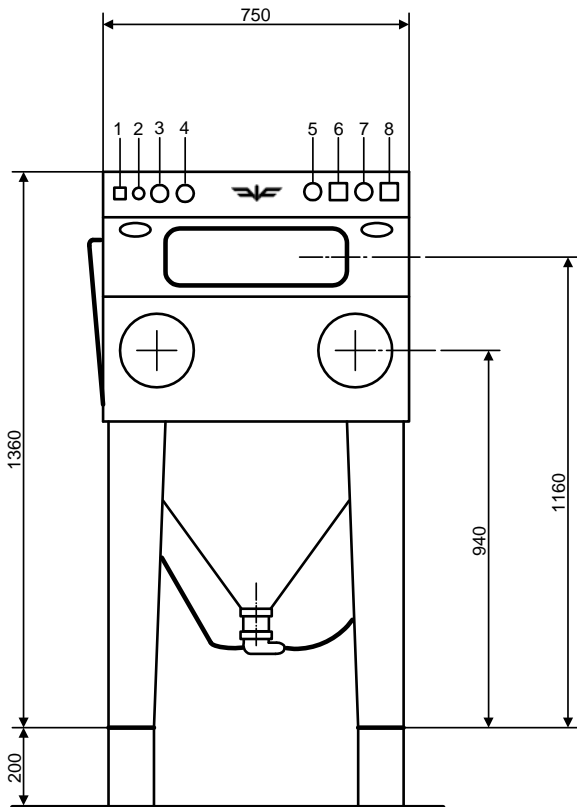

Legend:

- | | |
|--|---|
| 1 Main switch | 5 Pressure regulator for moving injector |
| 2 Control safety | 6 Manometer for moving injector |
| 3 Potentiometer for ventilator | 7 Pressure regulator for microblasting pistol |
| 4 Potentiometer for microblasting agent drying system (Pos. 4 only on request as an optional accessory) | 8 Manometer for microblasting pistol |

Usable space:

Width 740 x depth 480 x height 300 mm.
Optimal for surface treatment of workpieces with dimensions of width 500 x depth 400 x height 200 mm

Operating voltage:

230 V + PE / 50/60 Hz

Power consumption:

136 W

Control safety:

4 AT

Compressed-air connection:

| | |
|------------------------------|------------|
| On the side of the building | 1/2" G |
| On the side of the equipment | 1/4" G |
| Pressure | 0 - 10 bar |

Sound level:

68 dB(A) without microblasting
75 dB(A) with microblasting at 3 bar

Weight:

| | |
|------------------------------------|---------|
| Microblasting equipment: | 105 kg |
| Moveable structural aluminium rack | 12,5 kg |

All data are given without liability on our part. We reserve the right to modify constructional design at any time.

Sales / Development

iepcO ag
Hofstrasse 21
CH-8181 Höri
Phone +41 / (0)44 861 16 16
Fax +41 / (0)44 860 63 86
www.iepcO.ch

Production Plant

iepcO ag
Steiächerweg 10
CH-5316 Leuggern
Phone +41 / (0)56 268 80 40
Fax +41 / (0)56 268 80 50
info@iepcO.ch