

Microblasting Equipment PEENMATIC 550



Tabletop Microblasting Equipment



- Standard equipment:**
- Service door, which is operated with cylinders, supported by compressed gas, with integrated sight window, provided with a safety glass and an attrition-proof glass in a quick change frame
 - Door interruption switch
 - Working grate made of perforated plate, two-piece, detachable, diameter of holes 5 mm
 - Gloves, exchangeable
 - Microblasting pistol unit, type EF 3, with hard metal blasting nozzle HSD 5/10, adjustable via pressure reducing valve, 0 - 8,0 bar, microblasting pressure reading on the manometer
 - Continuous drying system for microblasting agents, 50 W, electronically continuously adjustable, including covering for heating element
 - Microblasting agent pre-accelerating system with moving injector, adjustable via pressure reduction valve, 0 - 4 bar, pressure reading on the manometer
 - Automatic, selective microblasting agent recycling system
 - Built-in high surface microfilter system with one filter cartridge. Automatic, electro-pneumatic filter cleaning
 - Dust collecting drawer, made of steel
 - Ventilator for high surface microfilter unit, electronically continuously variable
 - Blow-out pistol (air-blasting pistol)
 - Foot actuated switch with impulse contact
 - Compressed-air connection, 1/4", at equipment, including oil and water separator
 - Control panel with all necessary switches and control elements
 - Key-operated switch, on / off, with 2 keys
 - Illumination, 1 x 11 W

- Optional accessories:**
- Movable structural aluminium rack, with 2 tin plates
 - Hour counter of microblasting time
- (on request)

Sales / Development
iepcO ag
Hofstrasse 21
CH-8181 Höri
Phone +41 / (0)44 861 16 16
Fax +41 / (0)44 860 63 86
www.iepcO.ch

Production Plant
iepcO ag
Steiächerweg 10
CH-5316 Leuggern
Phone +41 / (0)56 268 80 40
Fax +41 / (0)56 268 80 50
info@iepcO.ch

**Technologies for
perfect surfaces**

Microblasting Equipment PEENMATIC 550

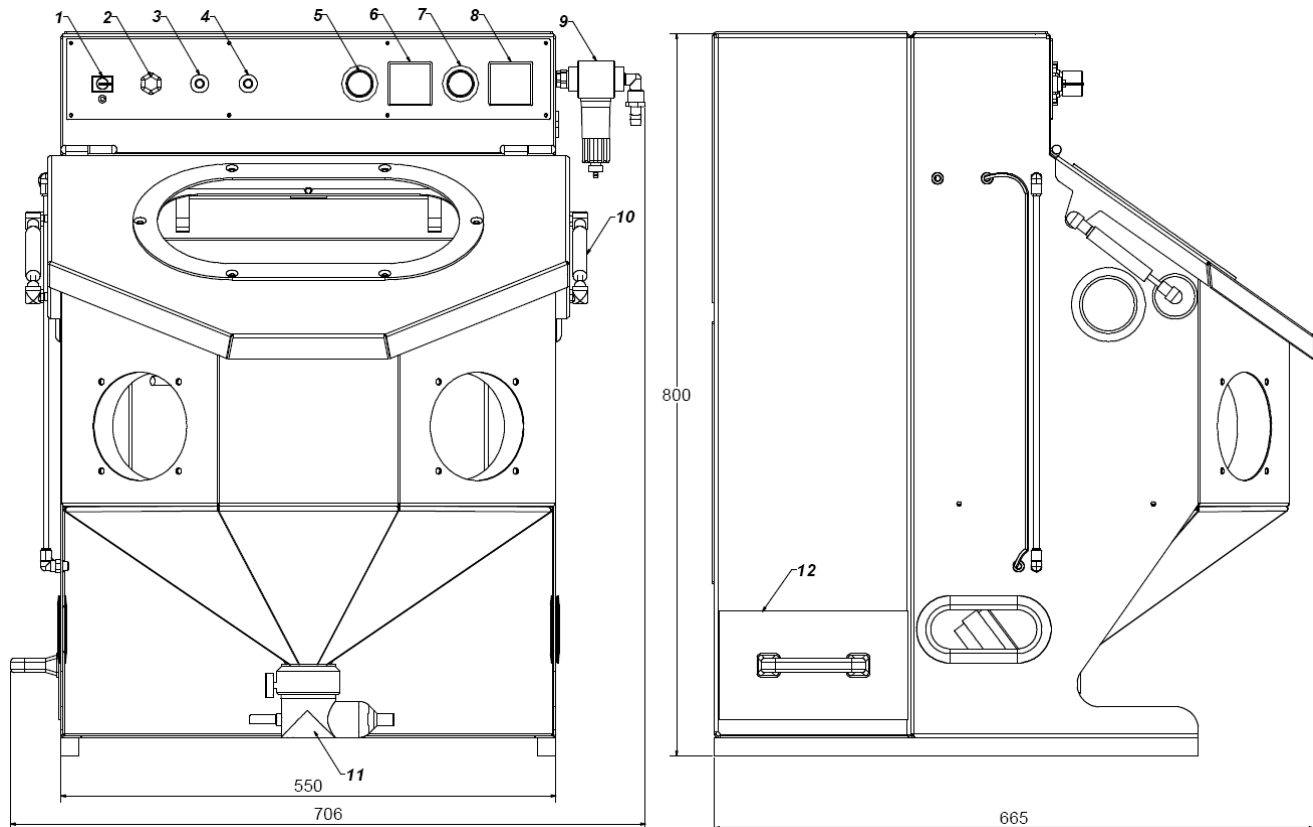

Legend:

- | | |
|---|---|
| 1 Key-operated switch | 7 Pressure regulator for microblasting pistol |
| 2 Control safety | 8 Manometer for microblasting pistol |
| 3 Potentiometer for ventilator | 9 Oil and water separator with tube connector |
| 4 Potentiometer for microblasting agent drying system | 10 Gas compression spring |
| 5 Pressure regulator for moving injector | 11 Moving injector |
| 6 Manometer for moving injector | 12 Dust collecting drawer |

Usable space:

Width 450 x depth 300 x height 300 mm

Operating voltage:

230 V + PE / 50/60 Hz

Power consumption:

125 W

Control safety:

4 AT

Compressed-air connection:

On the side of the building	1/2" G
On the side of the equipment	1/4" G
Pressure max.	10 bar

Sound level:

58 dB(A) without microblasting
65 dB(A) with microblasting at 3 bar

Weight:

77 kg

All data are given without liability on our part. We reserve the right to modify constructional design at any time.

Sales / Development

iepco ag
Hofstrasse 21
CH-8181 Höri
Phone +41 / (0)44 861 16 16
Fax +41 / (0)44 860 63 86
www.iepco.ch

Production Plant

iepco ag
Steiächerweg 10
CH-5316 Leuggern
Phone +41 / (0)56 268 80 40
Fax +41 / (0)56 268 80 50
info@iepco.ch