

C 60

The gigantic version



C 60

5-axes / 5-sided
machining up to 2,500 kg



The C 60 U –
at home in all fields

Tool and mould making
Highly dynamic simultaneous
5-axes machining up to a
component weight of 2,500 kg

Aerospace
Precision in perfection

Mechanical engineering
Fully automatic and flexible
manufacturing systems

Motor sport
Highest precision at
high availability

Subcontract industry
Dynamic, precise and reliable





C 60

Dynamic in a new dimension

3 axes in the tool
component independent dynamics

Pick-up magazine
integrated in the base, thereby saving space

stainless steel lining
of the entire working area

Working area with optimised swarf ejection
dry machining

Swivelling range
of the NC swivelling rotary tables $+130^\circ$ to -130°

Large working area
relative to the machine footprint

Accessibility
very good ergonomics

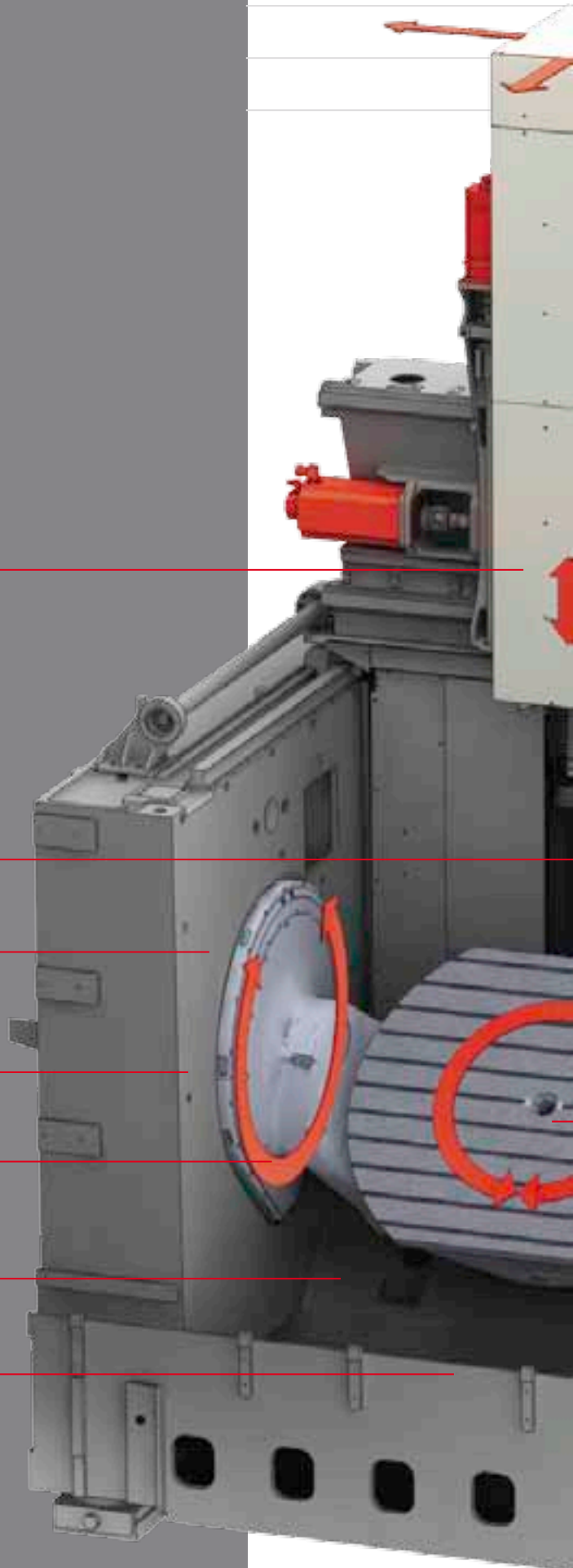

DYNAMICS

ACCURACY

COMPACTNESS

SURFACE QUALITY

AVAILABILITY

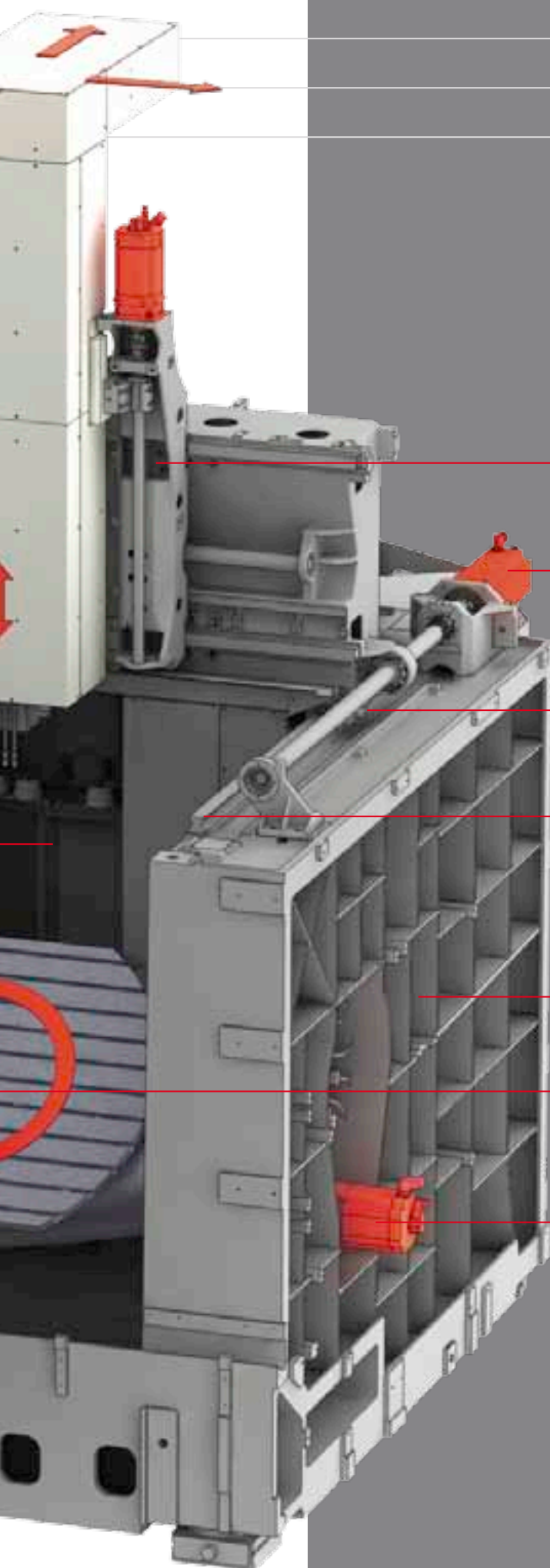

Tandem drive (Z-axis)
for high machine dynamics in the Z-axis

Tandem drive (Y-axis)
for high machine dynamics in the Y-axis

Force characteristics
3 guideways with one guideshoe
for ideal force balance

Linear axes
above the working area

Modified gantry design
with ideal main axis support

Torquemotor (C-axis)
for high dynamics

Tandem drive (A-axis)
avoidance of torsion and high accuracy



Construction



Large workpiece dimensions

Workpiece diameter max. Ø 1200 mm / workpiece height max. 900 mm

Coolant tank

with large coolant volume

Central cable routing

integrated into the machine enclosure

Encapsulated working area

with automatic top and laminated glass safety panes

Crane loading

door opening max. 1450 mm

Platform extending

along the entire front of the machine

Control panel

ergonomically pivotable, height-adjustable and with tiltable 19" screen

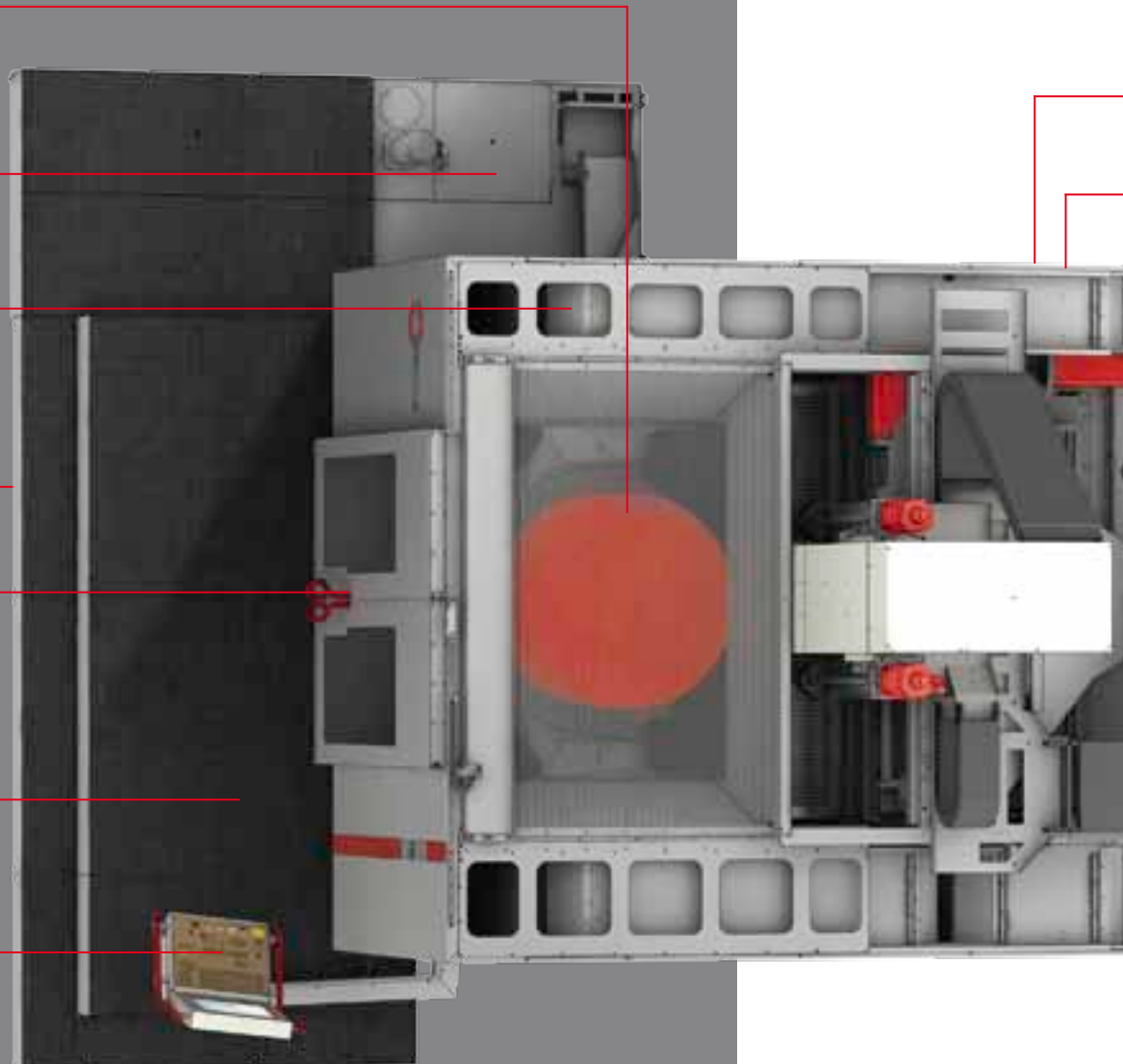



Fluidbox
with latest bus technology

Service door
for maintenance work and service activities

Central cooling
for the entire machine

Magazine loading and unloading point
for ergonomic/
ground-level tool loading

Central switch cabinet
with air-conditioning unit

Design principle

- Modified gantry design
- Three axes in the tool, thus workpieces independent dynamics, ideal pre-requisite for rapid traverses and feed up to 50 m/min
- Modular configuration of the table and expansion variants in the multi-functional machine base
- Drives and guideways outside / above the working area
- Compact design, thus little space required
- Complete transport
- No foundation required
- Optimised static and dynamic properties
- Maximum utilisation, positioning and long term accuracy
- High dynamics in the machining process
- Short positioning and start times on account of high acceleration of 6 m/s²

Drives and guideways

- Y slide as a traverse rests on 3 carriages with 3 staggered guideways
- Tandem drives in A-, Y- and Z-axes
- Good guideway ratio of the traverse which is moved by a tandem drive on both sides near the outer guides
- Roller recirculating guideways in all linear axes, thus constant dynamic conditions
- Digital AC servo motors with pretensioned ball screws
- Permanent position monitoring by absolute, optical measuring systems in all axes
- Low-maintenance automatic central grease lubrication system

Tool change

- Automatic tool change in cycle
- Ring magazine 70 / 50 tools as SK 40, HSK A 63, SK 50 or HSK A 100, integrated in the machine base unit
- Protected outside the work area and thus minimised risk of tools becoming soiled

Electronics

- Digital drives
- Absolute measuring systems
- Latest control technologies
- Frequency-based recovery of the braking energy into the mains
- Switch cabinet with air-conditioning unit

Machine

ADVANTAGES OF A UNIQUE MACHINE CONCEPT

LARGEST WORKING AREA RELATIVE TO THE INSTALLATION SURFACE

UNIQUE AXIS CONCEPT

SHORT CHIP-TO-CHIP TIMES ON ACCOUNT OF INTEGRATED TOOL MAGAZINE

ONE-PIECE MACHINE BED PROVIDES STABLE STRUCTURE

CONSISTENT MODULAR DESIGN FROM THE STANDARD MACHINE
TO THE FLEXIBLE MACHINING CENTRE

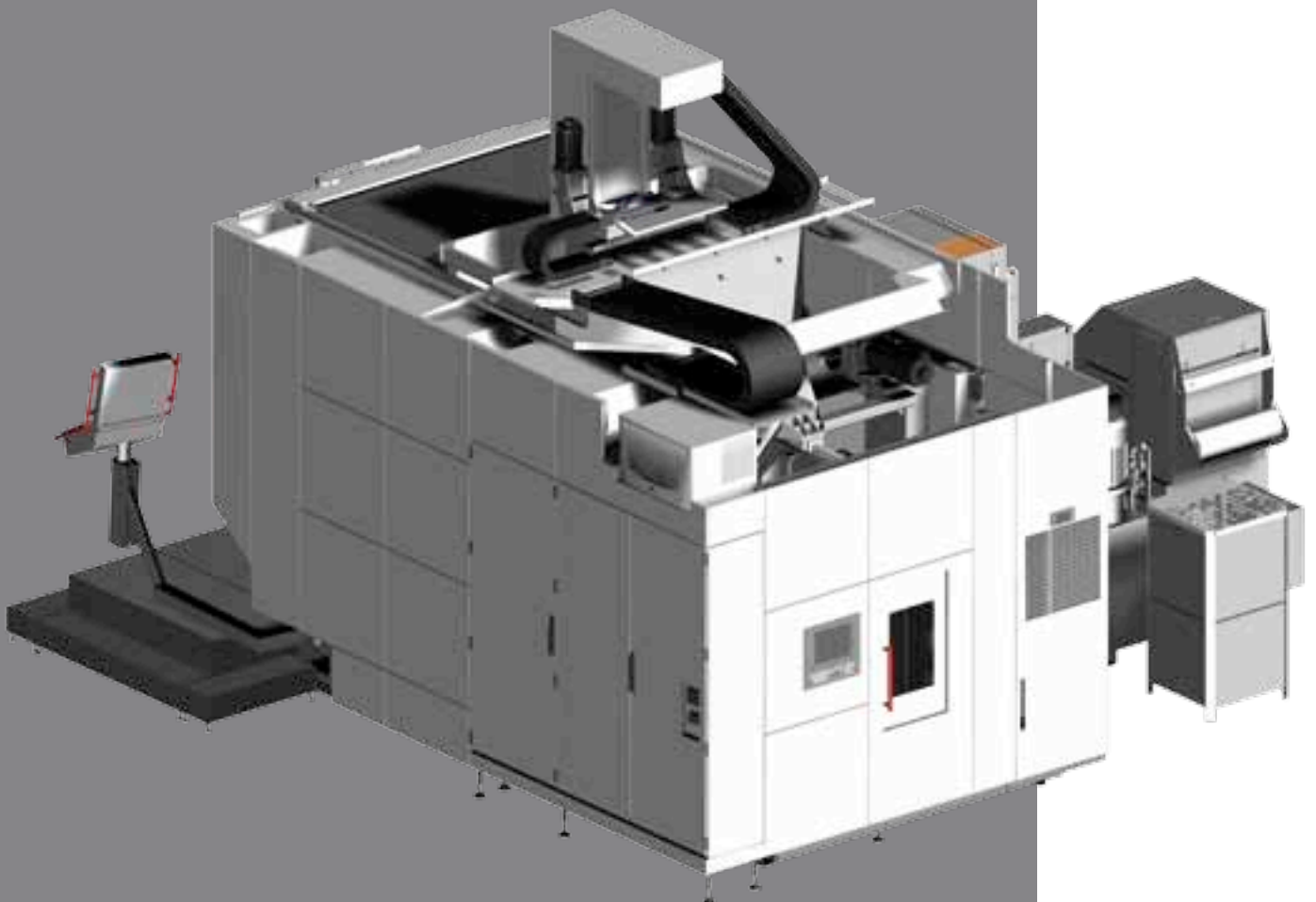

Working area

Traverse	
X-Y-Z	1,200-1,300-900 mm
Rapid linear traverse	
X-Y-Z	50 m/min
Linear acceleration	
X-Y-Z	6 m/s ²

Main spindle drive

Speed	9,000, 10,000, 12,000 15,000, 18,000 rpm.
Max. torque	up to 476 Nm
Max. output	up to 56 kW

Tool changer (pick up)

Magazine position	70/50
Chip-to-chip time*	approx. 9.5 s

Control

Heidenhain	iTNC530
Siemens	S 840 D SL

also available as MT version

*[chip-to-chip times in accordance with VDI 2852, sheet 1]



Table variants

What makes our table concept so special



SWIVELLING AXIS A IN THE COMPONENT

Complicated 5-axis machining processes are carried out by comparatively small traverses of the linear axes

VERY LARGE COLLISION CIRCLE

Optimum utilization of the working area

TANDEM DRIVE

Torsion-free highly dynamic positioning of the swivelling axis A

TORQUE DRIVE

Highly dynamic movements in the rotary axis

SEPARATION OF THE ROTARY AND SWIVELLING AXES

User and programmer friendly based on easy follow-up of the table movements

TABLE LOAD

High masses on all table variants



NC-controlled swivelling rotary table

Clamping surface:	Ø 900 mm
T-grooves:	parallel 7 / 18 H7
Swivel range:	+/- 130°
Speed - swivelling axis A:	15 rpm.
Speed - rotary axis C:	30 rpm.
Type of drive axis C:	torque
Maximum table load:	2,500 kg



NC-controlled swivelling rotary table

Clamping surface:	Ø 1,350 x 1,100 mm
Max. workpiece circle monitoring:	Ø 1,400 mm
T-grooves:	parallel 11 / 22 H7
Swivel range:	+/- 130°
Speed - swivelling axis A:	15 rpm.
Speed - rotary axis C:	30 rpm.
Type of drive axis C:	torque
Maximum table load:	2,500 kg

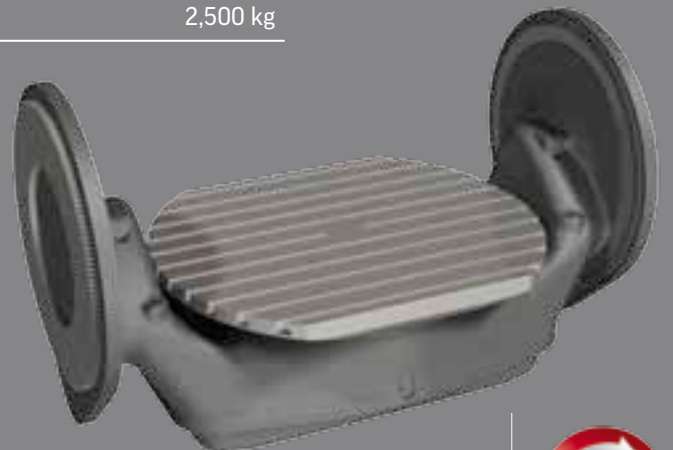

Spindles

HIGH-TECH SPINDLES FOR DEMANDING MILLING PROCESSES

SLIM-END SPINDLE FOR MACHINING DEEPER CAVITIES

FEW IRREGULAR EDGES (PREVENTION OF COLLISION)

Spindle

Spindle speed:	9,000 rpm.
Interface:	SK 50
Max. torque:	356 Nm
Max. output:	56 kW

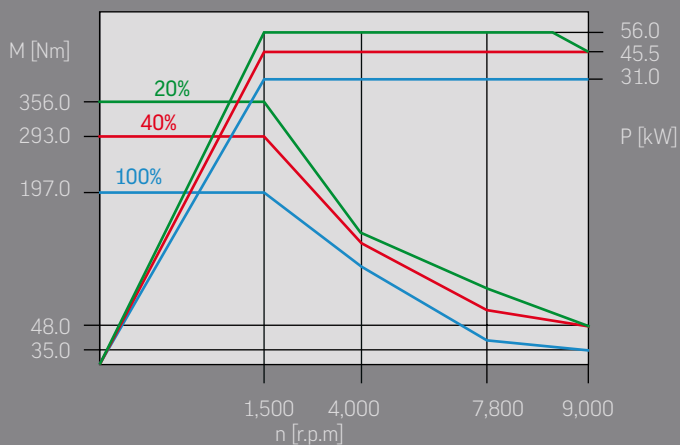

Spindle

Spindle speed:	9,000 rpm.
Interface:	HSK A 100
Max. torque:	476 Nm
Max. output:	41 kW

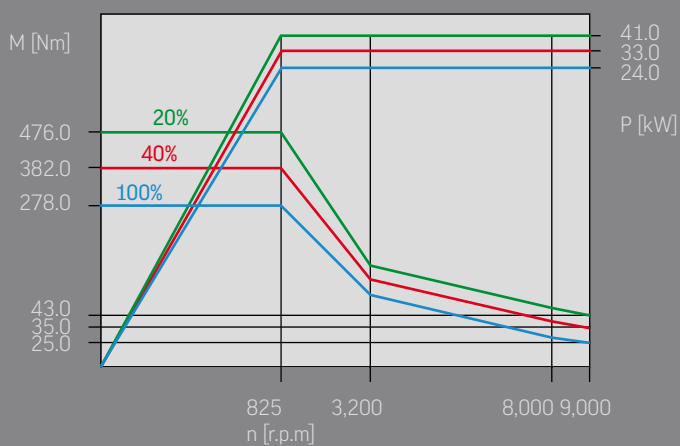

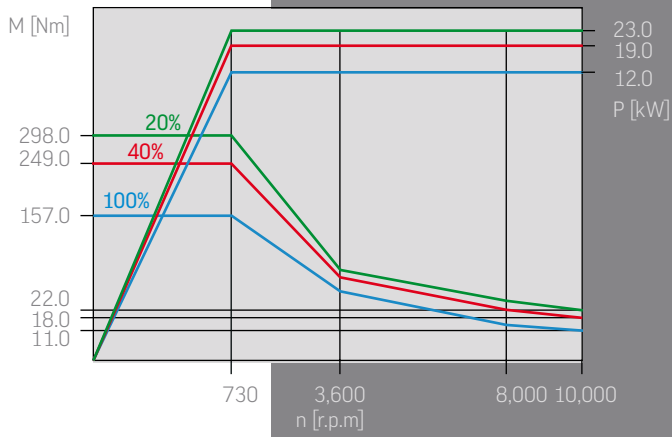

Spindle

Spindle speed:	10,000 rpm.
Interface:	HSK A 63
Max. torque:	298 Nm
Max. output:	23 kW

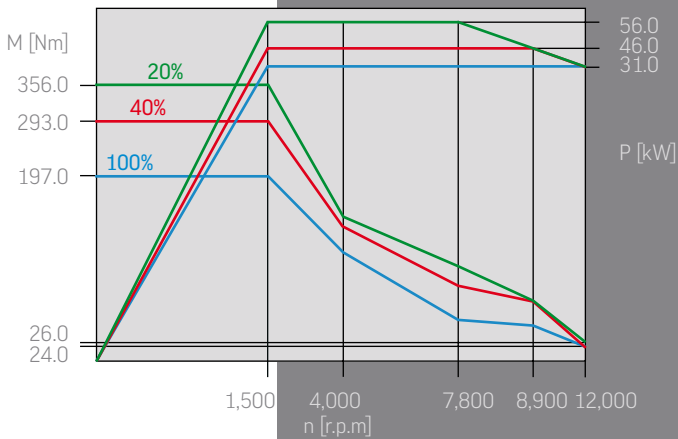

Spindle

Spindle speed:	12,000 rpm.
Interface:	HSK A 100
Max. torque:	356 Nm
Max. output:	56 kW

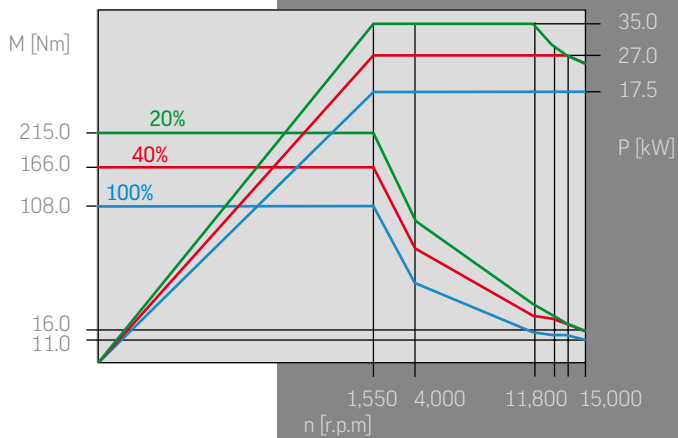

Spindle

Spindle speed:	15,000 rpm.
Interface:	SK 40
Max. torque:	215 Nm
Max. output:	35 kW

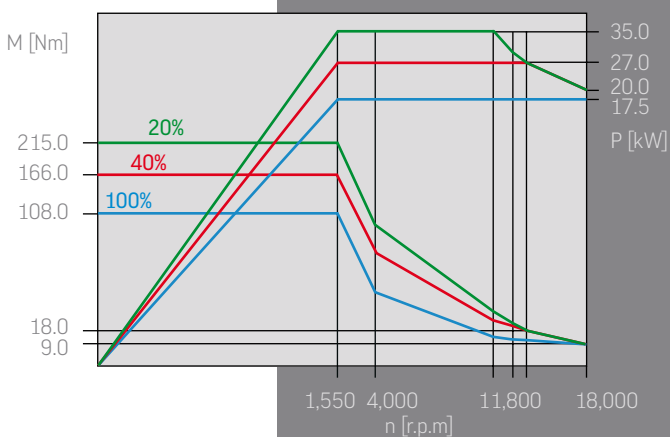

Spindle

Spindle speed:	18,000 rpm.
Interface:	HSK A 63
Max. torque:	215 Nm
Max. output:	35 kW

Magazine

INTEGRATION INTO THE MACHINE BASE

VERY GOOD ACCESSIBILITY

ERGONOMIC LOADING AND UNLOADING POINT ON THE BACK OF THE MACHINE

LOADING HANDLING FOR THE PICK-UP MAGAZINE

COVERS FOR THE SPINDLE TAPERS

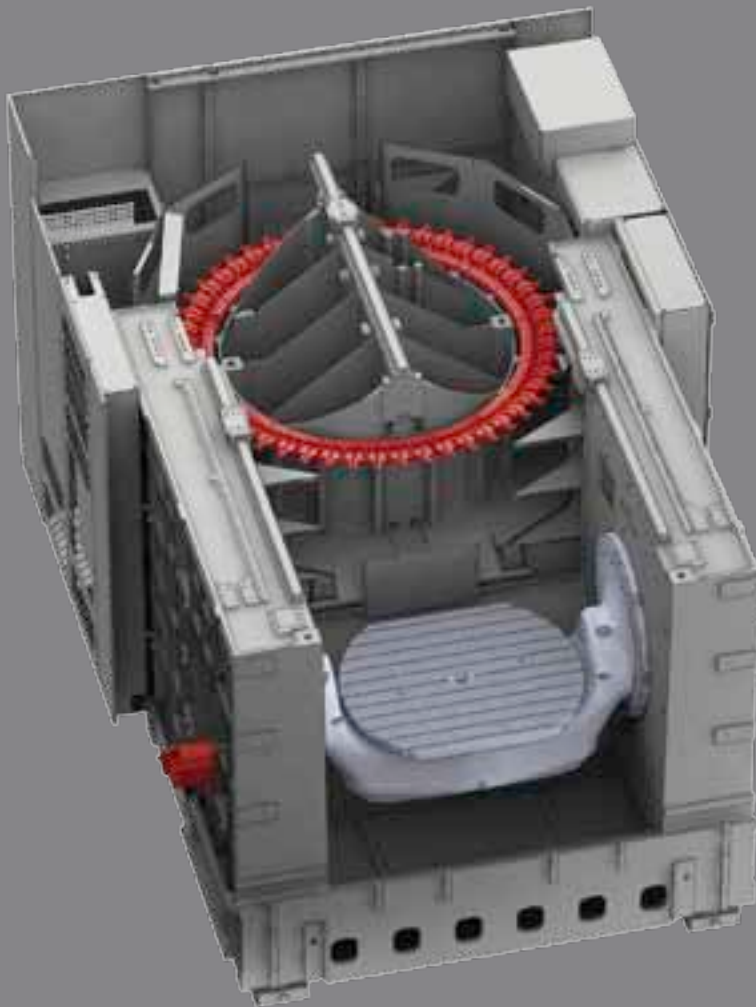

Tool changer (pick-up)

Interface:	SK 40 / HSK A 63	SK 50 / HSK A 100
Chip-to-chip time*:	approx. 9.5 s	approx. 9.5 s
Magazine positions:	70	50
Maximum tool length:	500 mm	500 mm
Maximum tool diameter:	Ø 160 mm	Ø 250 mm
Maximum tool weight:	15 kg	30 kg
Max. full magazine load:	560 kg	550 kg

Additional magazines on demand

*(chip-to-chip times in accordance with VDI 2852 sheet 1)

Controls

HEIDENHAIN iTNC 530 OR SIEMENS S 840 D SL

3D SOFTWARE

19" TFT-TECHNOLOGY

USER DEFINED SOFTKEYS

ERGONOMIC CONTROL PANEL

CONTROLS FOR DEMANDING MILLING PROCESSES

Whether for tool and mould making, in production or in high-speed machining, they stand out for their many advantages.

SAFE CONTROLS

Controls with integrated safety technology keeping with category 3 described in European standard EN 13849-1.

E-MESSENGER

Increases the availability of the machines and minimises production failures.

TELESERVICE

Teleservice ensures even faster support in case of programming and operating problems.

HERMLE WDS

The Maintenance Diagnostic System (WDS) makes it possible to record informative values and evaluate them, thus facilitating preventive and status-oriented maintenance and efficient diagnostics in case of malfunctions.



Screen pivots 30°

Control panel vertically adjustable +/-100 mm

Practical slide-in tray

Details

HIGH SAFETY STANDARDS IN DAY-TO-DAY OPERATION

SAFETY ENCLOSURE FEATURING CASSETTE DESIGN

SPINDLE SERVICE - REPAIR OR EXCHANGE

COMPLETE TRANSPORT WITHOUT DISASSEMBLY,
EVEN FOR FUTURE MACHINE CONVERSIONS

ALL UNITS ARE ARRANGED TO FACILITATE EASY
MAINTENANCE AND SERVICING



Fast and convenient - safety enclosure with attractive cassette design. Fast access for service work with no need to completely disassemble the entire machine enclosure (saves time and money for service work).



At a glance - excellent accessibility to all units for maintenance and service tasks, yet still attractively integrated into the safety enclosure (prevents unauthorised access).



Dimensions

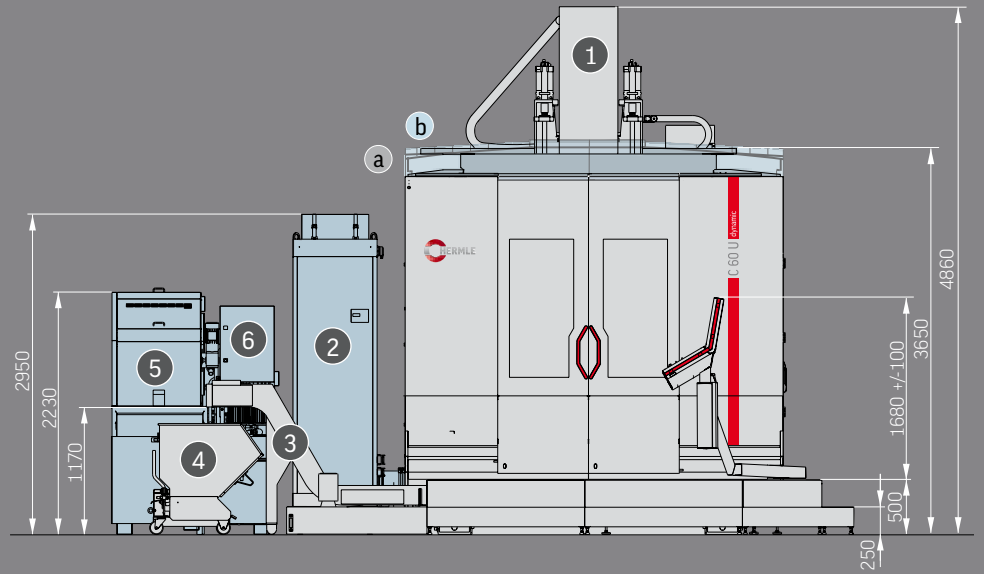

- 1 Machine
- 2 Oil mist extractor
- 3 Chip conveyor
- 4 Chip cart
- 5 Through the spindle coolant supply
- 6 recooling unit
- a Roof section standard machine

also available as MT version

- b Roof section MT version

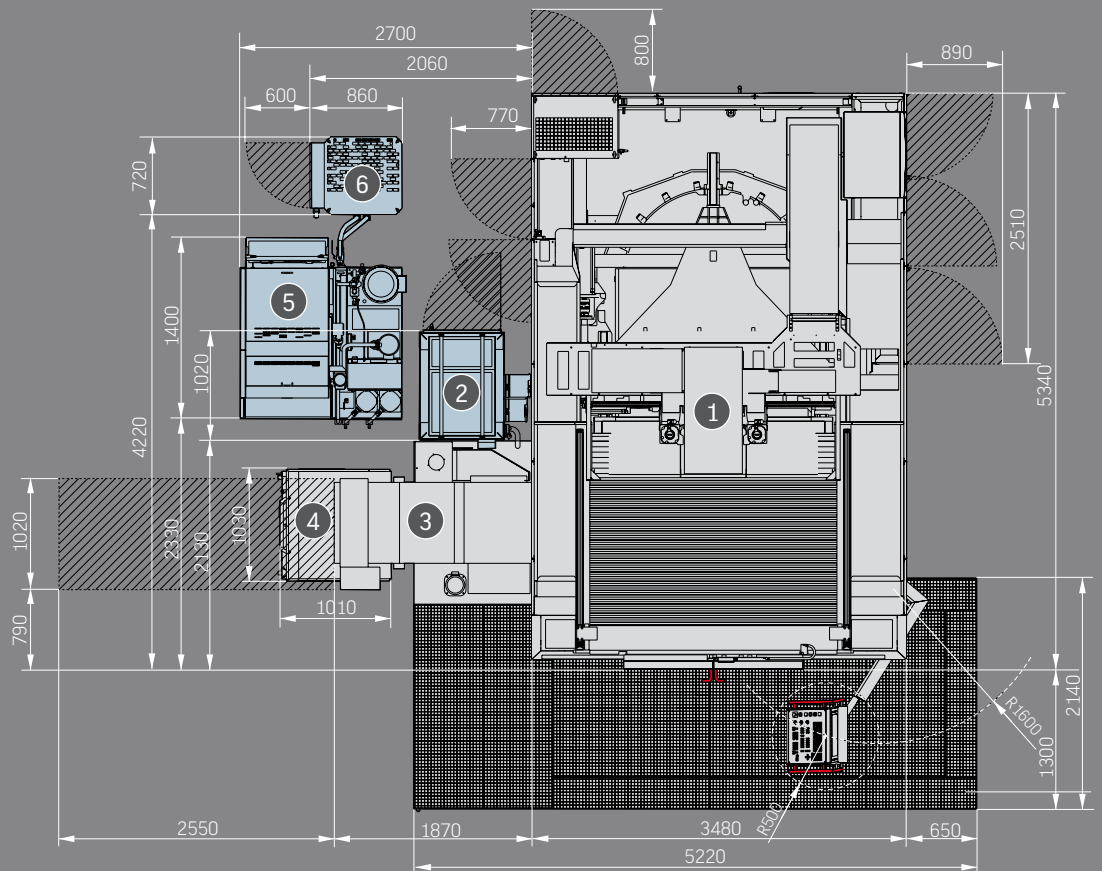

Technical Data

Working area	Traverse	X axis	1,200 mm
	Traverse	Y axis	1,300 mm
	Traverse	Z axis	900 mm
	Linear rapid traverse	X-Y-Z	50 m/min
	Linear acceleration	X-Y-Z	6 m/s ²
	Linear feed force	X-Y-Z	16,000 N
	Width across flats		1,100 mm
	Diameter of permissible workpiece		Ø 1,200 mm
	Height of permissible workpiece		900 mm

Main spindle drive	Speed	9,000 rpm.	SK 50	●
	Main power / torque	20% c.d.f.	56 kW / 356 Nm	
	Speed	9,000 rpm.	HSK A 100	●
	Main power / torque	20% c.d.f.	41 kW / 476 Nm	
	Speed	10,000 rpm.	HSK A 63	●
	Main power / torque	20% c.d.f.	23 kW / 298 Nm	
	Speed	12,000 rpm.	HSK A 100	●
	Main power / torque	20% c.d.f.	56 kW / 356 Nm	
	Speed	15,000 rpm.	SK 40	●
	Main power / torque	20% c.d.f.	35 kW / 215 Nm	
	Speed	18,000 rpm.	HSK A 63	■
	Main power / torque	20% c.d.f.	35 kW / 215 Nm	

Control unit	Heidenhain	iTNC 530	■
	Siemens	Sinumerik 840 D SL	●

Tool changer (pick up)	Interface	SK 40 / HSK A 63	SK 50 / HSK A 100	●
	Magazine pockets	70	50	
	Chip-to-chip time*	approx. 9.5 s	approx. 9.5 s	
	*(chip-to-chip times were determined in accordance with VDI 2852, sheet 1)			
	Maximum tool length	500 mm	500 mm	
	Maximum tool diameter	Ø 160 mm	Ø 250 mm	
	Maximum magazine load	560 kg	550 kg	

Connection-values (machine)	Mains connection	400 V / 50 Hz	400 V / 50 Hz
	Power consumption	78 kVA	90 kVA
	Compressed air	6 bar	6 bar

Weight	(Standard version)	approx. 30.0 t
--------	--------------------	----------------

Transport dimensions C 60 (basic machine)	Width	3,500 mm
	Depth	5,600 mm
	Height	4,870 mm

Hermle AG reserves the right to carry out modifications without prior notification, which may lead to deviating technical data.

Table variants	NC-controlled swivelling rotary table	Ø 900 ●	Ø 1,350 ●
	Clamping surface	Ø 900 mm	Ø 1,350 mm
	2 sided flattened to	-	1,100 mm
	Swivel range	+ 130° / - 130°	+ 130° / -130°
	Speed - swivelling axis A	15 rpm.	15 rpm.
	Speed - rotary axis C	30 rpm.	30 rpm.
	Maximum table load	2,500 kg	2,500 kg
	T-grooves parallel	7 / 18H7	11 / 22H7
Position measuring system direct	Resolution		0.0001 mm ■
Position tolerance	Tp in X-Y-Z-axis keeping with German standard VDI/DGQ 3441 <small>(determined at 20° Celsius +/- 1° Celsius constant ambient temperature. Our products are subject to German export laws and exports have to be approved as the achievable accuracy may be smaller / equal than 6 µm.)</small>		0.008 mm ■
Coolant system	Amount of coolant		550 l ■
	Pump performance		5 bar / 80 l/min
Internal coolant supply with paper tape filter	Amount of coolant		1,500 l ●
	Pressure (infinitely variable manuel)		max. 80 bar / 26 l/min
	Mains connection		400 V / 50 Hz
	Power consumption		18.5 kVA
Chip conveyor	Scraper belt		■
	Hinged belt conveyor		●
	Ejection height of chip conveyor		1,100 l
	Chip cart		450 l ●
Hydraulic system	Operating pressure		120 bar ■
Central lubrication system	Minimum quantity lubrication		■

Options

Automatic cabin door	●
Rotating clear-view window	●
Electrical heat compensation	●
Electrical hand-held control module	●
Touch probe including preparation	●
Preparation for touch probe	●
Tool breakage monitoring / measuring system	●
Coolant nozzle	●
Minimal quantity lubrication internal + external	●
Air blast through the spindle centre	●
Bed flushing	●
BDE signal	●
Oil mist extractor	●
Air purge for linear scales	●
Status lamp	●

For technical data of the MT version, please see the brochure "MT Series"

- standard equipment
- to order

Hermle

all over the world

GERMANY

Hermle + Partner Vertriebs GmbH
Phone +49 (0)7426 95-0 info@hermle-hpv.de
Fax +49 (0)7426 95-6109 www.hermle-partner-vertrieb.de

Hermle-Leibinger Systemtechnik GmbH
Phone +49 (0)7461 96628-0 info.hls@hermle.de
Fax +49 (0)7461 96628-398

Hermle Maschinenbau GmbH
Phone +49 (0)89 6735950-0 info@hermle.de
Fax +49 (0)89 6735950-11 www.hermle.de

Hermle Demo Centre Kassel-Lohfelden
Phone +49 (0)561 5103879 awt.kassel@hermle.de
Fax +49 (0)561 5103889

SWITZERLAND

Hermle (Schweiz) AG
Phone +41 (0)52 67400-40 info@hermle-schweiz.ch
Fax +41 (0)52 67400-41 www.hermle-schweiz.ch

Hermle WWE AG
Phone +41 (0)41 768 51-51 info@hermle-wwe.com
Fax +41 (0)41 768 51-50

AUSTRIA

Hermle Österreich
Rudolf Fluch
Phone +43 (0)3863 20044 rudolf.fluch@hermle.co.at
Fax +43 (0)3863 20054

Florian König
Phone +43 (0)5244 62373 florian.koenig@hermle.co.at
Fax +43 (0)5244 62378

ITALY

Hermle Italia S.r.l.
Phone +39 02 95327-241 info@hermle-italia.it
Fax +39 02 95327-243 www.hermle-italia.it

THE NETHERLANDS

Hermle Nederland B.V.
Phone +31 (0)77 396 176 1 info@hermle-nederland.nl
Fax +31 (0)77 464 1070 www.hermle-nederland.nl

BELGIUM

Sales Office Belgium
Phone +32 (0)13 5563-83 hermle@scarlet.be
Fax +32 (0)13 5563-84

DENMARK, FINLAND, NORWAY

Hermle Nordic
Phone +45 66 17 69 50 lars.lynge@hermle-nordic.dk
Fax +45 66 17 61 09 www.hermle-nordic.dk

BULGARIA

Hermle Southeast Europe
Phone +359 2 958 59 01 info@hermle.bg
Fax +359 2 859 83 99 www.hermle.bg

CZECH REPUBLIC

Hermle Česká Republika
Miloš Branda
Phone +420 272 652 340 milos.branda@hermle.cz
Fax +420 272 652 977

Martin Skukálek
Phone +421 326 523 048 martin.skukalek.hpv@stonline.sk
Fax +421 326 523 050

USA

Hermle Machine Co. LLC
Phone +1 414 421-9770 info@hermlemachine.com
Fax +1 414 421-9771 www.hermlemachine.com

CHINA

Hermle China
Shanghai Representative Office
Phone +86 21 2281 9188 hermlesha@126.com
Fax +86 21 6427 1887

Beijing Representative Office
Phone +86 10 5822 0951/2/3 hermlebeijing@vip.163.com
Fax +86 10 5822 1426

RUSSIA

000 Hermle Vostok
Representative Office of Hermle WWE AG
Moscow
Phone +7 495 221 83 68 info@hermle-vostok.ru
Fax +7 495 221 83 93 www.hermle-vostok.ru

Representative Office of Hermle WWE AG
St. Petersburg
Phone +7 812 702 67 32 spb@hermle-wwe.com
Fax +7 812 702 67 33

Representative Office of Hermle WWE AG
Togliatti
Phone +7 8482 51 76 48 tlt@hermle-wwe.com
Fax +7 8482 51 76 47

The machining examples used in this leaflet are published with the explicit and friendly approval of our customers. The information in this leaflet only contains general descriptions or performance characteristics which in a real application do not always meet the description or which may change by further development of the products. The requested performance parameters shall be binding only, if they are explicitly agreed within the sales contract.

Subject to technical modifications • 04/10/060/4000/EN/ST • Printed on paper bleached without chlorine



Maschinenfabrik
Berthold Hermle AG
Industriestraße 8-12
D-78559 Gosheim
Phone +49 (0)7426 95-0
Fax +49 (0)7426 95-6109
info@hermle.de
www.hermle.de