

FOR SIMPLE MEASUREMENT THE RULE OF
THUMB IS SUFFICIENT.
FOR THE REST THERE IS MARCAL.



The latest information on MARCAL products can be found on our website:

www.mahr.com, WebCode 203

► | High-quality calipers are amongst the most important measuring instruments in Dimensional Metrology because they are both versatile and easy to use, such as the MarCal series from Mahr. The ER digital caliper series is simple to operate, has a large, easy to read display and enables fast and uncomplicated data transmission thus meeting all requirements of modern metrology. The new generation of Mahr calipers is the MarCal 16 EWR a waterproof digital caliper, which enables measurement even in the most difficult workshop conditions. In addition all the Mahr calipers have a highly precise slide movement as well as both the slide and beam being made of hardened stainless steel thus completing the outstanding characteristics of Mahr calipers.

▶ | MarCal. Calipers

Overview

MarCal Calipers

1- 2

Standard Calipers

MarCal 16 EWR

Waterproof Caliper with a Digital Display

1- 4

MarCal 16 ER

With a Digital Display

1- 8

MarCal 16 DN / 16 FN / 16 GN / 16 N

With a Line Scale (Vernier)

1-10

MarCal 16 U

With a Circular Scale

1-11

Universal Calipers

MarCal 16 EWW

With a Digital Display

1-12

Special Calipers

MarCal 16 EWR

Waterproof Caliper in special design

1-14

Workshop Calipers

MarCal 18 EWR / 18 ESA

With a Digital Display

1-20

MarCal 18 NA / 18 N / 18 DN

With a Line Scale (Vernier)

1-23

Depth Calipers

MarCal 30 EWR / 30 ER / 30 EWN

With a Digital Display

1-26

MarCal 30 N / 30 NH / 30 ND

With a Line Scale (Vernier)

1-30

Linear Machine Scales

MarCal 31 EW

With a Digital Display

1-31

MarCal. Calipers

OVERVIEW

MarCal - Design Features

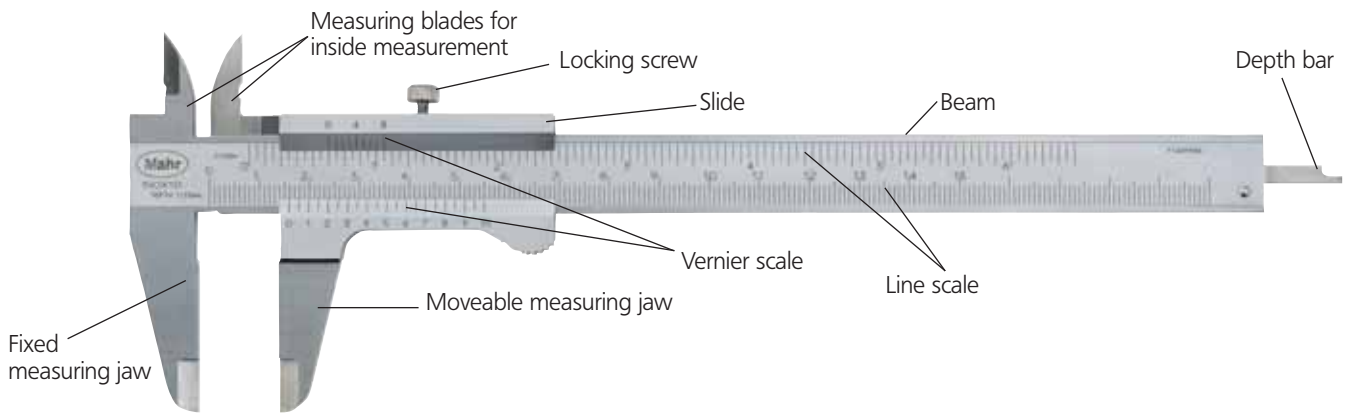

MarCal - Types on measurement

Calipers of the 16 series (e.g. 16 EWR, 16 U, 16 FN) can be used for 4 different measurements:

a) Outside measurement

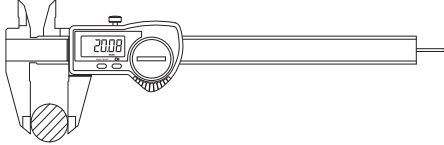

b) Inside measurement

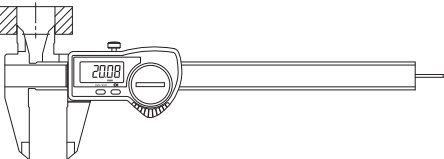

c) Depth measurement

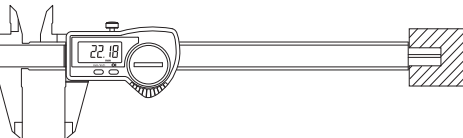

d) Step (Distance) measurement

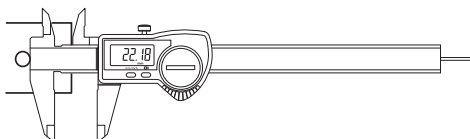

Error limits G according to DIN 862

Measuring length	Error limits G in μm		
	Scale interval and/or vernier interval	Resolution	
/	0.1 and 0.05	0.02	0.01
50	50	20	20
100			
200			
300	60	30	30
400			
500			
600			
700	90	40	40
800			
900			
1000			
1200			
1400	140	50	—
1600			
1800			
2000			
2200			
2400			

MarCal - The innovative Reference-System

Just set once to zero

All Mahr digital calipers with this logo **REFERENCE** are equipped with the innovative Reference-System. The zero position just has to be set once: after setting the zero position, the zero remains stored for all further measurements. Therefore, once the caliper is switched ON or the slide is moved the caliper is immediately ready for measurement. The need to reset to zero with a conventional caliper once the caliper is switched on has now become obsolete.

Conventional

① Switch ON

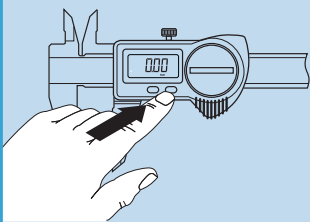

② Close the measuring jaws

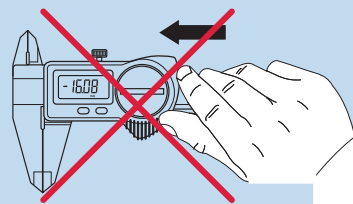

③ Set to zero

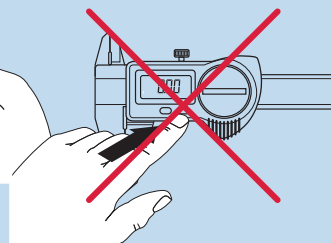

④ Results of measurement

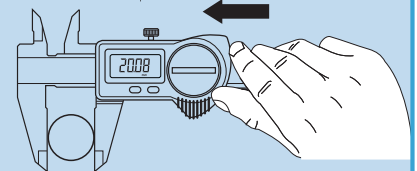

REFERENCE - System

① Switch ON

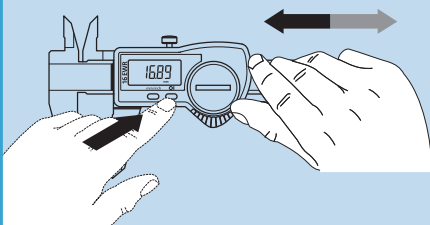

Press the ON key or move the slide

REFERENCE

② Results of measurement

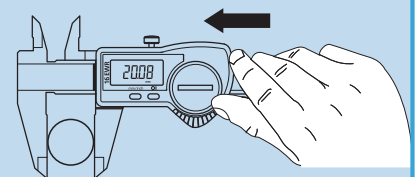

IP-Protection classes

First digit is the degree of protection according to IEC 60529		Second digit is the degree of protection according to IEC 60529 (approximate)	
Protection against particles, contaminants and dust		Protection against wet conditions (fluids)	
0	Not protected	0	Not protected
1	Particles > 50.0 mm	1	Falling water drops - vertical
2	Particles > 12.5 mm	2	Falling water drops - tilted < 15°
3	Particles > 2.5 mm	3	Spray water < 60°
4	Particles > 1.0 mm	4	Water splashing from all directions
5	Dust protected	5	Water jets from all directions
6	Dust tight	6	Powerful water jets
		7	Temporary immersion in water
		8	Continuous immersion in water



Example:
IP67 means that the product is "Dust tight" and is protected against "Temporary immersion in water".

MarCal. The new Generation with the Reference-System

WATERPROOF CALIPERS

▶ | The water-proof digital caliper **MarCal** 16 EWR, with protection class IP67 and the Reference Lock-Function, ensures both accurate and reliable results even in the most toughest workshop conditions. | ◀

The high-contrast display with 8.5 mm high digits enables accurate, fatigue free reading of the measurement results.



Universal SPC-interface (optional). You have a choice of **MarConnect** data outputs, select either **USB**, **Digimatic** or **Mahr Opto RS232**

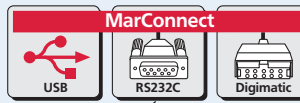

The **Reference-Lock-Function** prevents operating error caused by accidental usage of the operating buttons.

The new Reference system is extremely energy efficient as when the caliper is in standby mode; almost no power is required, thus **extending the life of the battery to up to 50%**.

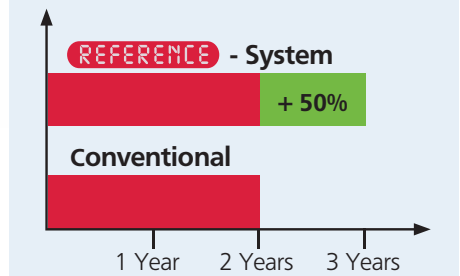

Lapped measuring faces for accurate measurement.



MarCal calipers have **lapped guide way surfaces**, these guarantee an even and sensitive run of the slide.

Surface of the guide way



Lapped guide way

Code Initials	IP	International Protection
First digit	6	Dust-tight
Second digit	7	Protected against temporary immersion in water



Protection class **IP67** in accordance to IEC 60529, the water proof measuring system **FPS** (Fluid Protected measuring System) with a sealed housing.

Digital Caliper MarCal 16 EWR





Features

Functions:

- ON/OFF
- RESET (Set display to zero)
- mm/inch
- Reference-Lock/Unlock
- Auto-ON/OFF
- Immediate measurement due to the Reference system
- Excellent resistance against dust, coolants and lubricants, protection class IP67
- Dirt wipers are integrated in the slide
- Life of the battery up to 3 years
- Max measuring speed 2.5 m/s (100"/s)
- High contrast Liquid Crystal Display with 8.5 mm high digits
- Lapped guide way
- Slide and beam made of hardened stainless steel
- Measuring blades for inside measurement
- Step measuring function
- Locking screw
- Supplied with: Case, battery, operating instructions

Technical Data

Measuring range		Resolution	Error limit G	Depth rod		Friction wheel	Order no.
mm	(inch)	mm/inch	mm				
150	(6")	0.01/ .0005"	0.03	●	●		4103060
150	(6")	0.01/ .0005"	0.03		●		4103062
150	(6")	0.01/ .0005"	0.03	●		●	4103061
150	(6")	0.01/ .0005"	0.03		●	●	4103063

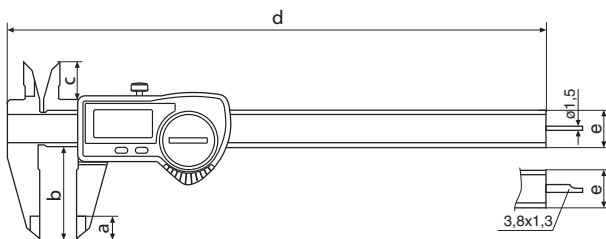

Dimensions

mm	a	b	c	d	e
150	10	40	16	235	16 x 3
200	10	50	19	285	16 x 3.5
300	14	64	19	388	16 x 4

Accessories

	Order no.
Depth Measuring Bridge	16 Em 4102020
Battery 3V, Type CR 2032	4102520

16 Em

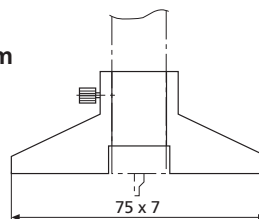

Digital Caliper MarCal 16 EWR with data output

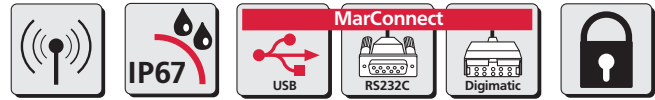

REFERENCE

Features

Functions:

- ON/OFF
- RESET (Set display to zero)
- mm/inch
- Reference-Lock/Unlock
- DATA (Data transmission via connection cable)
- Auto-ON/OFF
- Immediate measurement due to the Reference system
- Excellent resistance against dust, coolants and lubricants, protection class IP67
- MarConnect data output, choose alternatively: USB, OPTO RS232C or Digimatic
- Dirt wipers are integrated in the slide
- Life of the battery up to 3 years
- Max measuring speed 2.5 m/s (100"/s)
- High contrast LCD with 8.5 mm high digits
- Lapped guide way
- Slide and beam made of hardened stainless steel
- Measuring blades for inside measurement
- Step measuring function
- Locking screw
- Supplied with: Case, battery, operating instructions

Technical Data

Measuring range	Resolution	Error limit G		Depth rod		Friction wheel	Order no.
		mm/inch	mm/inch				
150 (6")	0.01/ .0005"	0.03/ .001"	●	●	●	4103064	
150 (6")	0.01/ .0005"	0.03/ .001"	●	●	●	4103066	
200 (8")	0.01/ .0005"	0.03/ .001"	●	●	●	4103068	
300 (12")	0.01/ .0005"	0.04/ .0015"	●	●	●	4103070	
150 (6")	0.01/ .0005"	0.03/ .001"	●	●	●	4103065	
150 (6")	0.01/ .0005"	0.03/ .001"	●	●	●	4103067	
200 (8")	0.01/ .0005"	0.03/ .001"	●	●	●	4103069	
300 (12")	0.01/ .0005"	0.04/ .0015"	●	●	●	4103071	

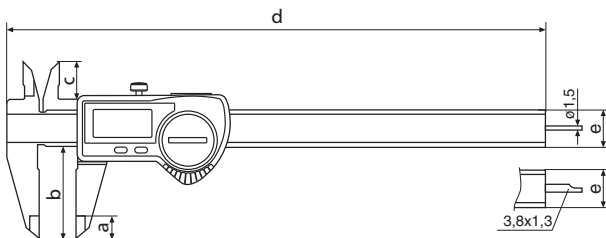

Dimensions

mm	a	b	c	d	e
150	10	40	16	235	16 x 3
200	10	50	19	285	16 x 3.5
300	14	64	19	388	16 x 4

Accessories

	Order no.
Depth Measuring Bridge	16 Em 4102020
Battery 3V, Type CR 2032	4102520
Data Connection Cable USB (2 m)	16 EXu 4102357
Data Connection Cable Opto RS232C (2 m), with SUB-D jack 9-pin	16 EXr 4102410
Data Connection Cable Digimatic (2 m), Flat plug 10-pin	16 EXd 4102411

Accessories for Data Processing see Chapter 11

Digital Caliper MarCal 16 EWR special design

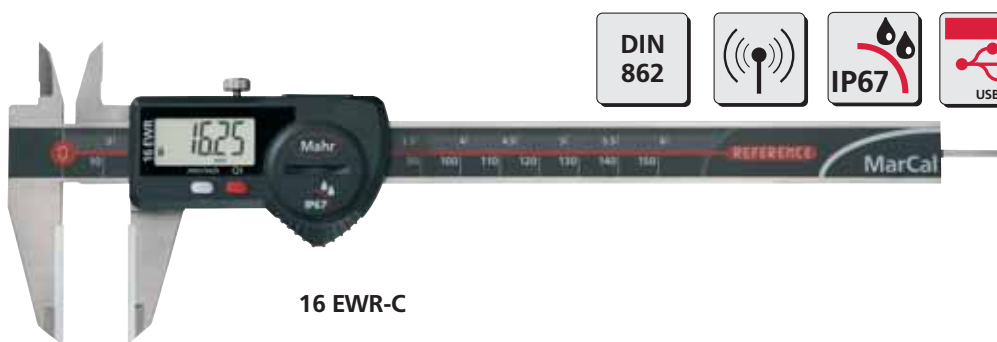

16 EWR-C



16 EWR-H

REFERENCE

Features

Features are the same as the MarCal 16 EWR, please refer to Page 1-6, additional features can be found in the Technical Data.

Technical Data

	Measuring range		Resolution	Error limit G	Depth rod 	Order no.	Type
	mm	(inch)					
16 EWR-C	150	(6")	0.01/.0005"	0.03	●	4103072	Ceramic outside measuring faces
16 EWR-H	150	(6")	0.01/.0005"	0.03	●	4103073	Carbide outside measuring faces

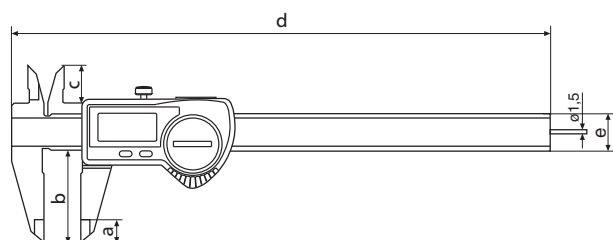

Dimensions

mm	a	b	c	d	e
150	10	40	16	235	16 x 3

Accessories

Battery, Data Connection Cables see Page 1 - 6

Accessories for Data Processing see Chapter 11

Digital Caliper MarCal 16 ER



DIN
862





REFERENCE

Features

Functions:

- ON/OFF
- RESET (Set display to zero)
- mm/inch
- Reference-Lock/Unlock
- Auto-ON/OFF
- Immediate measurement due to the Reference system
- Dirt wipers are integrated in the slide
- Life of the battery up to 3 years
- Max measuring speed 2.5 m/s (100"/s)
- High contrast Liquid Crystal Display with 8.5 mm high digits
- Lapped guide way
- Slide and beam made of hardened stainless steel
- Measuring blades for inside measurement
- Step measuring function
- Locking screw
- Supplied with: Case, battery, operating instructions

Technical Data

Measuring range		Resolution	Error limit G	Depth rod		Order no.
mm	(inch)	mm / inch	mm / inch			
150	(6")	0.01 / .0005"	0.03 / .001"	•		4103000
150	(6")	0.01 / .0005"	0.03 / .001"		•	4103001

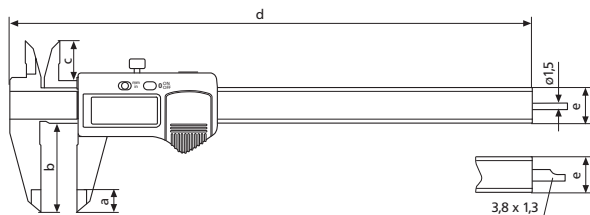

Dimensions

mm	a	b	c	d	e
150	10	40	16	233	16 x 3

Accessories

	Order no.
Depth Measuring Bridge	16 Em 4102020
Battery 3V, Type CR 2032	4102520

16 Em

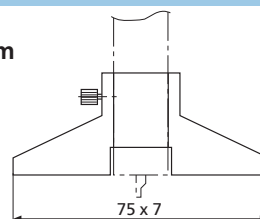

Digital Caliper MarCal 16 ER with data output





REFERENCE

Features

- Functions:**
- ON/OFF
 - RESET (Set display to zero)
 - mm/inch
 - Reference-Lock/Unlock
 - Auto-ON/OFF
- Immediate measurement due to the Reference system
 - MarConnect data output, choose alternatively: USB, OPTO RS232C or Digimatic
 - Dirt wipers are integrated in the slide
 - Life of the battery up to 3 years
 - Max measuring speed 2.5 m/s (100"/s)
 - High contrast Liquid Crystal Display with 8.5 mm high digits
 - Lapped guide way
 - Slide and beam made of hardened stainless steel
 - Measuring blades for inside measurement
 - Step measuring function
 - Locking screw
 - Supplied with: Case, battery, operating instructions

Technical Data

Measuring range		Resolution	Error limit G		Depth rod		Data output	Order no.
mm	(inch)	mm / inch	mm / inch	DIN 862				
150	(6")	0.01 / .0005"	0.03 / .001"	●	●		●	4103002
150	(6")	0.01 / .0005"	0.03 / .001"	●		●	●	4103003
200	(8")	0.01 / .0005"	0.03 / .001"	●		●	●	4103004
300	(12")	0.01 / .0005"	0.04 / .0015"				●	4103005

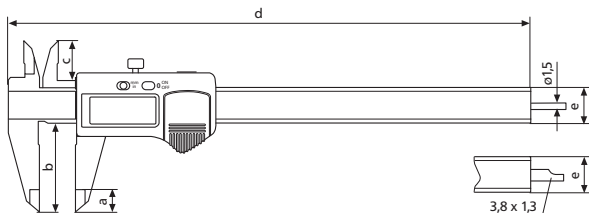

Dimensions

mm	a	b	c	d	e
150	10	40	16	235	16 x 3
200	10	40	16	285	16 x 3
300	14	64	18	388	16 x 4

Accessories

	Order no.
Depth Measuring Bridge	16 Em 4102020
Battery 3V, Type CR 2032	4102520
Data Connection Cable USB (2 m)	16 EXu 4102357
Data Connection Cable Opto RS232C (2 m), with SUB-D jack 9-pin	16 EXr 4102410
Data Connection Cable Digimatic (2 m), Flat plug 10-pin	16 EXd 4102411

Accessories for Data Processing see Chapter 11

16 Em

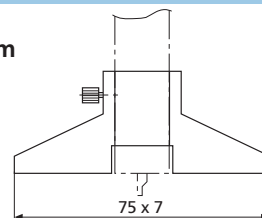

Vernier Calipers MarCal 16 N, 16 FN, 16 GN, 16 DN with scale reading

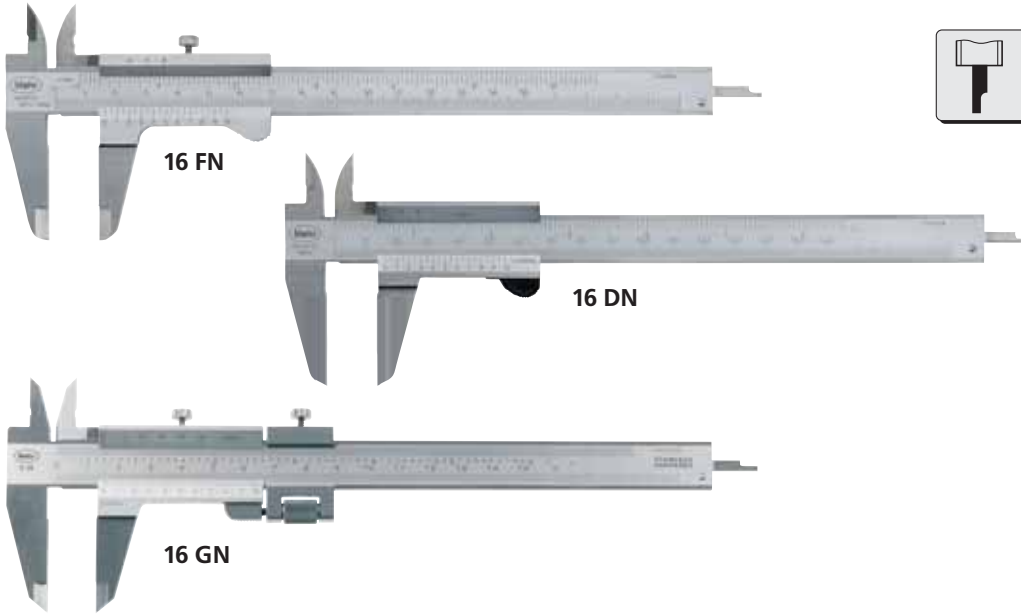

Features

- Vernier and main scale have a satin chrome finish for glare free reading
- Slide and beam made of hardened stainless steel
- Raised guide ways for the protection of the scale
- Measuring blades for inside measurement
- Step measuring function
- Depth bar
- Locking screw or thumb clamp
- Supplied with:
Plastic case and thread table

Technical Data

	Measuring range		Readings		Error limit G		Order no. without fine adjustment	Order no. with fine adjustment	Remarks
	mm	(inch)	upper inch	lower mm	mm	DIN 862			
16 FN	150			0.05	0.05	●	4100420		Locking screw above
16 FN	150	(6")	1/128"	0.05	0.05	●	4100400		
16 DN	150	(6")	1/128"	0.05	0.05	●	4100600		
16 N	150	(6")	1/128"	0.05	0.05	●	4100500		Locking screw below
16 GN	150			0.02	0.04		4100650	4100660*	
16 GN	150	(6")	.001"	0.02	0.04		4100670	4100680*	
16 FN	200			0.05	0.05	●	4100421		Locking screw above
16 FN	200	(8")	1/128"	0.05	0.05	●	4100401		
16 GN	200			0.02	0.05		4100651	4100661*	
16 GN	200	(8")	.001"	0.02	0.05		4100671	4100681*	
16 FN	300			0.05	0.05	●	4100422		Locking screw above
16 FN	300	(12")	1/128"	0.05	0.05	●	4100402		
16 GN	300			0.02	0.05		4100652	4100662*	
16 GN	300	(12")	.001"	0.02	0.05		4100672	4100682*	

* Calipers with fine adjustment the measuring range is shortened by 20 mm / 1"

Dimensions mm	a	b	c	d	e	f
150	10	40	16	228	16 x 3	3.8
200	14	50	19	290	17 x 3.5	3.8
300	16	64	23	404	20 x 4	4.8

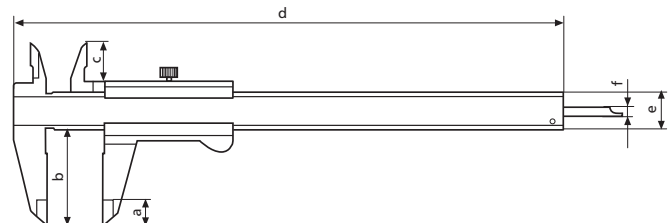

Accessories

	Order no.
Depth Measuring Bridge	16 Em 4102020
Leather case for meas. range 150 mm	4100302

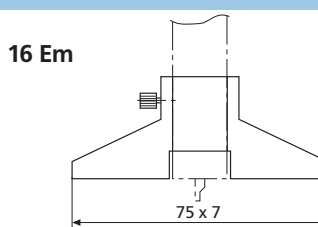

Vernier Caliper MarCal 16 U with circular scale

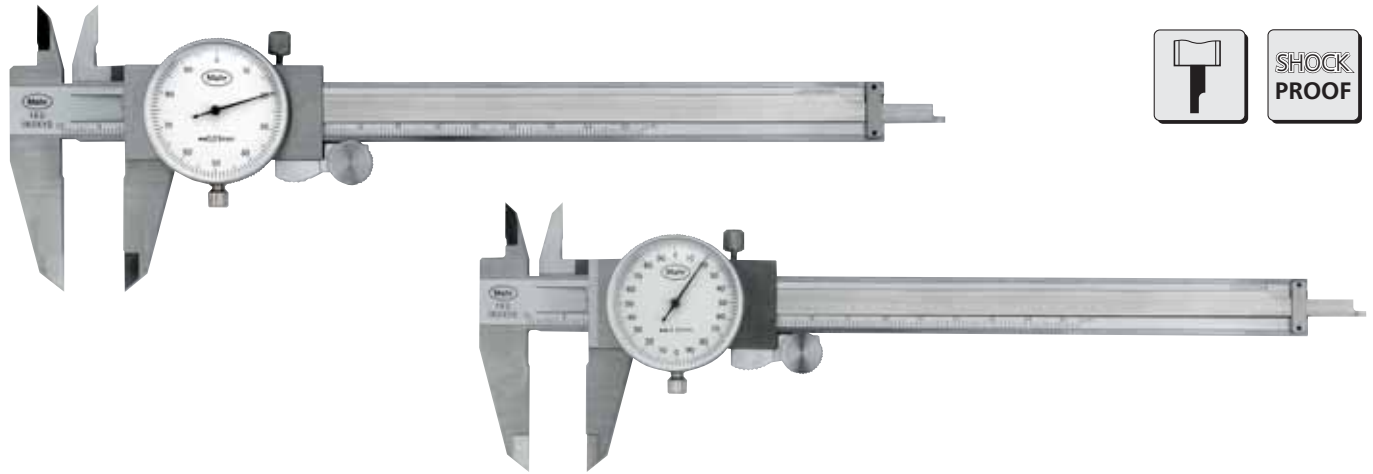

**SHOCK
PROOF**

Features

- Large, high contrast dial face
- Satin chrome finished line scale
- Shockproof movement
- Zero setting through rotating the dial face and locking screw
- Covered rack
- Slide and beam made of hardened stainless steel
- Measuring blades for inside measurement
- Step measuring function
- Locking screw
- Depth bar
- Supplied with: Plastic case
- Inch model is supplied with a black dial face

Technical Data

Measuring range	Readings	Diameter of circular scale	1 Pointer revolution	Dial face color	Error limit G	DIN 862	Bestell-Nr.
150 mm	0.01 mm	34 mm	1 mm	white	0.03 mm	●	4107005
150 mm	0.02 mm	34 mm	2 mm	white	0.03 mm	●	4107107
6"	.001"	1.3"	.100"	black	.0012"		4107900

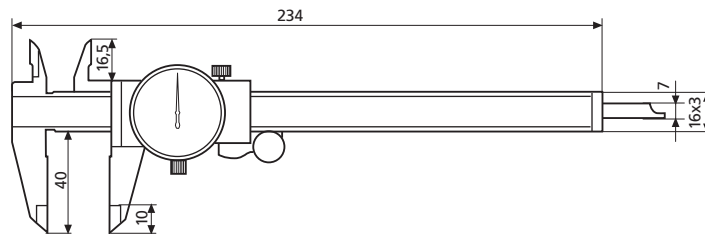

Accessories

	Order no.	16 Em
Depth Measuring Bridge	4102020	
Leather case for meas. range 150 mm	4100302	

Universal Digital Caliper MarCal 16 EWW in set

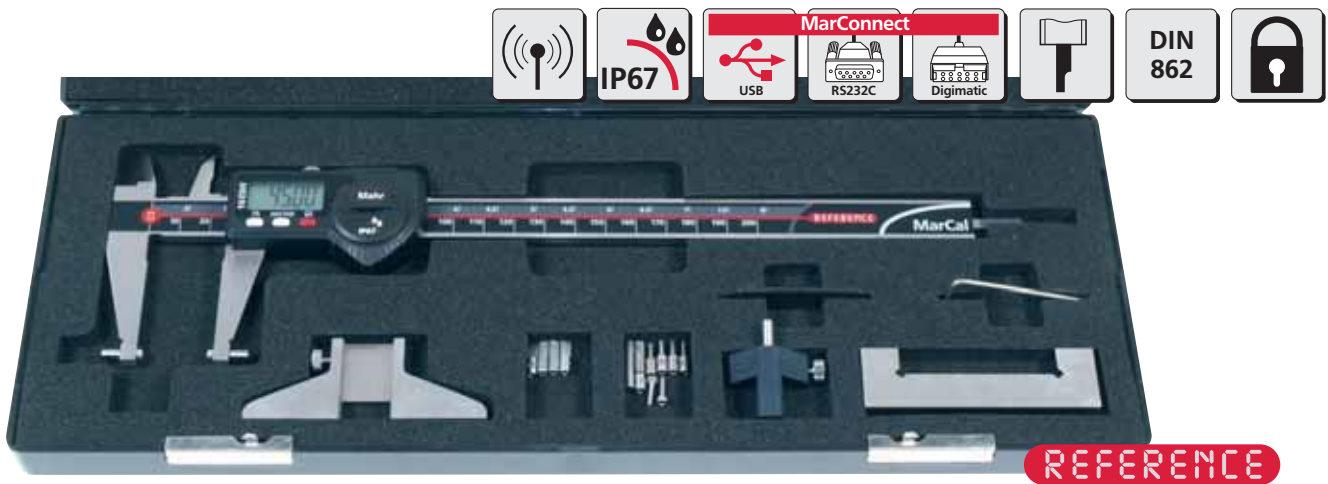

Applications

- The 16 EWW can also be used as a standard caliper (4 types of measurement).

When used in conjunction with the standard accessories; it is possible to measure recesses, grooves, etc.

In conjunction with the additional accessories; threads, bores, serrations, etc. can be measured.

Features

Functions:

ON/OFF
 RESET (Set display to zero)
 mm/inch
 Reference-Lock/Unlock
 PRESET (for entering a numerical value)
 DATA (Data transmission via connection cable)
 Auto-ON/OFF

- Immediate measurement due to the Reference system
- Excellent resistance against dust, coolants and lubricants, protection class IP67

- MarConnect data output, choose alternatively: USB, OPTO RS232C or Digimatic
- Dirt wipers are integrated in the slide
- Life of the battery up to 3 years
- Max measuring speed 2.5 m/s (100"/s)
- High contrast LCD with 8.5 mm high digits
- Lapped guide way

- Slide and beam made of hardened stainless steel
- Measuring blades for inside measurement
- Step measuring function
- Locking screw
- Supplied with: Case, battery, operating instructions

Technical Data

Measuring range*		Resolution	Error limit G	Order no.
mm	(inch)	mm / inch	mm	
200	(8")	0.01 / .0005"	0.03	4118807**
200	(8")	0.01 / .0005"	0.03	4118808***

* in conjunction with accessories the measuring range may change ** includes standard accessories *** excludes standard accessories

Accessories

	Order no.
Battery 3V, Type CR 2032	4102520
Data Connection Cable USB (2 m)	16 EXu 4102357
Data Connection Cable Opto RS232C (2 m), with SUB-D jack 9-pin	16 EXr 4102410
Data Connection Cable Digimatic (2 m), Flat plug 10-pin	16 EXd 4102411

Accessories for Data Processing see Chapter 11

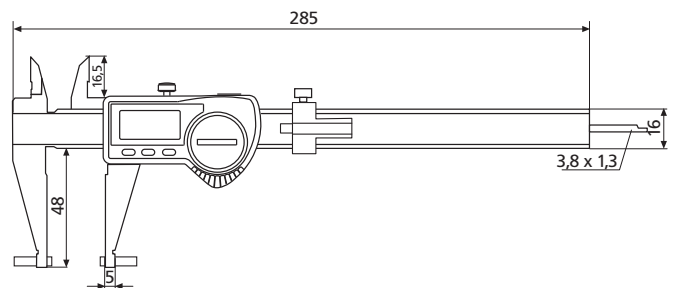

Universal Digital Caliper MarCal 16 EWW in set

Standard Accessories are included in the set

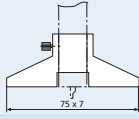
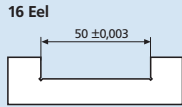
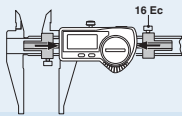
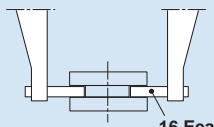
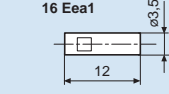
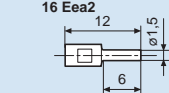
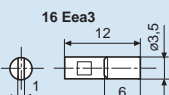
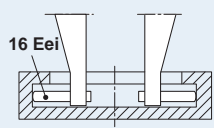
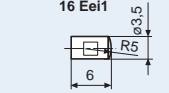
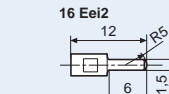
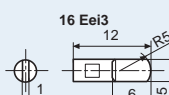
Catalog no.	Description	Order no.	Required quantity		Remarks
16 Em	Depth Measuring Bridge	4102020	1		
16 Eel	Setting Gage for inside measurement	4118817	1		
16 Ec	Measuring Force Device	4118818	1		
16 Eea 1	Anvils for outside measurements	4118810	2		 up to dia. 175 mm
16 Eea 2	Anvils for outside measurements	4118811	2		 up to dia. 175 mm
16 Eea 3	Anvils for outside measurements	4118812	2		 up to dia. 175 mm
16 Eei 1	Anvils for inside measurement	4118813	2		 from dia. 27 mm
16 Eei 2	Anvils for inside measurement	4118814	2		 from dia. 39 mm
16 Eei 3	Anvils for inside measurement	4118815	2		 from dia. 39 mm
	Screws M2 x 8	4879602	2		

Additional Accessories

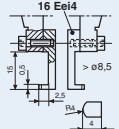
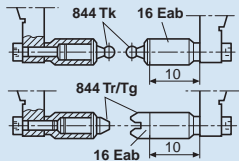
Catalog no.	Description	Order no.	Required quantity		Bemerkung
16 Eei 4	Anvils for inside measurement	4118816	2		from dia. 8.5 mm
16 Eab	Mounting Attachment for 844Tg/Tr and 844 Tk	4118819	2		see Page 10-10
844 Tk	Ball Anvils		2		see Pages 10-12/10-14
844 Tg/Tr	Thread Anvils		1 + 1		

Digital Caliper MarCal 16 EWR special design

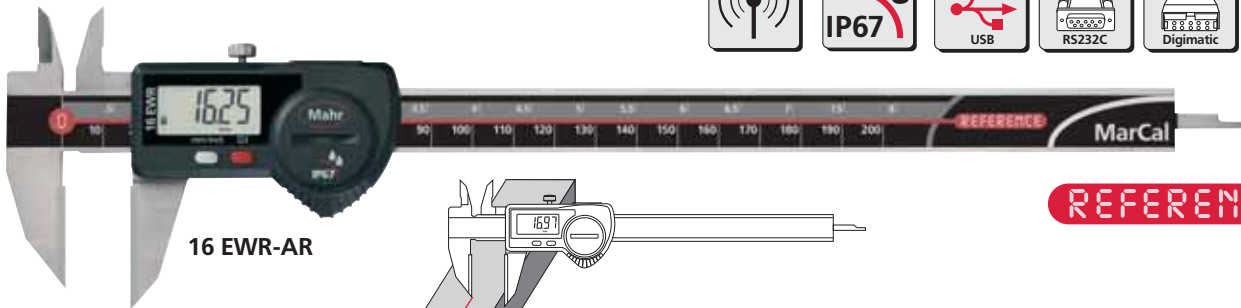
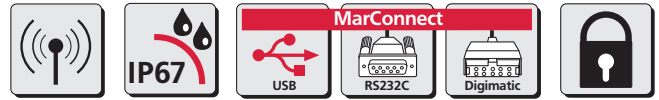

16 EWR-AR

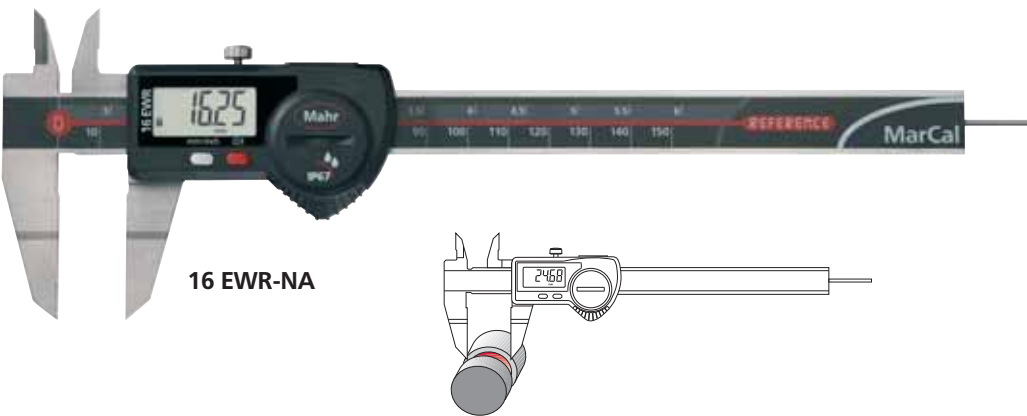





16 EWR-NA

Features

Features are the same as the MarCal 16 EWR, please refer to Page 1-6, additional features can be found in the Technical Data.

Technical Data

	Measuring range	Resolution	Error limit G	Depth rod	Order no.	Type
	mm (inch)	mm/inch	mm	 		
16 EWR-AR	200 (8")	0.01/ .0005"	0.03		4103082	Scribing/marking caliper
16 EWR-NA	150 (6")	0.01/ .0005"	0.03		4103074	Keyseat caliper

16 EWR-AR

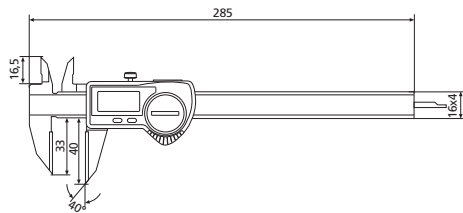

16 EWR-NA

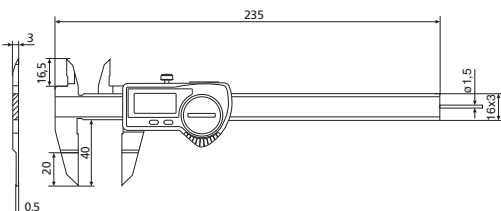

Dimensions

mm	a	b	c	d	e
150	10	40	16	235	16 x 3
200	10	40	16	235	16 x 3
300	10	40	16	235	16 x 3

Accessories

Battery, Data Connection Cables see Page 1 - 6

Accessories for Data Processing see Chapter 11

Digital Caliper MarCal 16 EWR special design

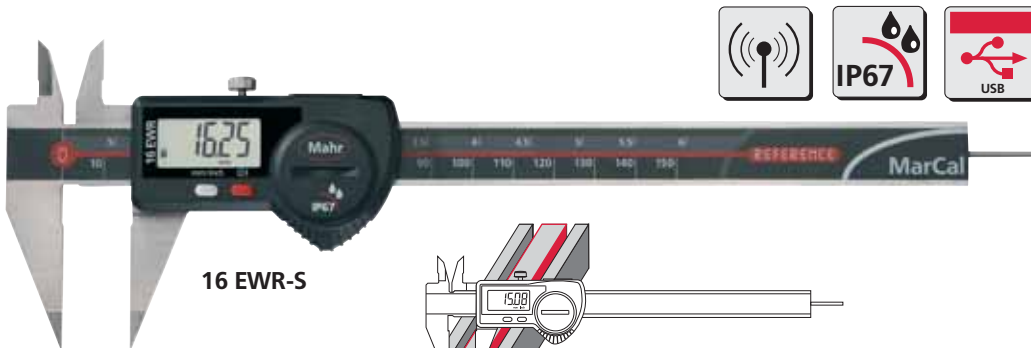

16 EWR-S

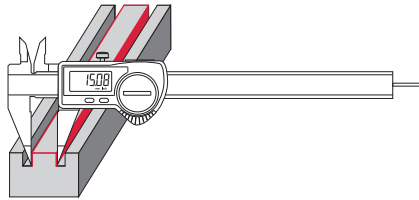

16 EWR-SM

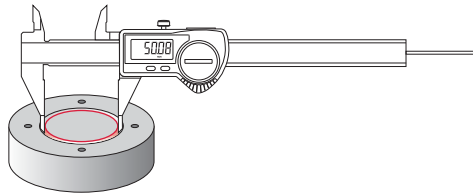

REFERENCE

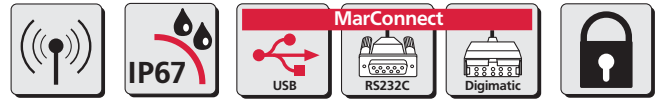

Features

Features are the same as the MarCal 16 EWR, please refer to Page 1-6, additional features can be found in the Technical Data.

Technical Data

	Measuring range		Resolution	Error limit G	Depth rod 	Order no.	Type
	mm	(inch)	mm/inch	mm			
16 EWR-S	150	(6")	0.01 / .0005"	0.03	●	4103075	Pointed caliper
16 EWR-SM	150	(6")	0.01 / .0005"	0.03	●	4103076	Caliper with pointed meas. jaws

16 EWR-S

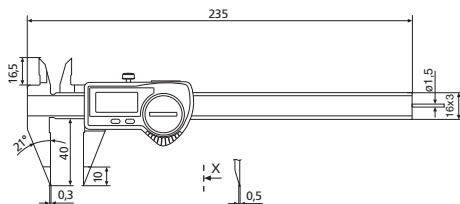

Dimensions

mm	a	b	c	d	e
150	10	40	16	235	16 x 3

16 EWR-SM

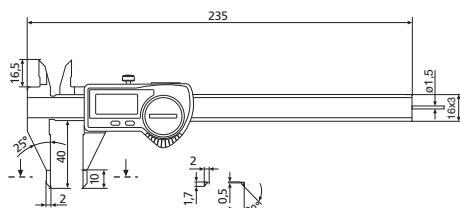

Accessories

Battery, Data Connection Cables see Page 1 - 6

Accessories for Data Processing see Chapter 11

Digital Caliper MarCal 16 EWR special design

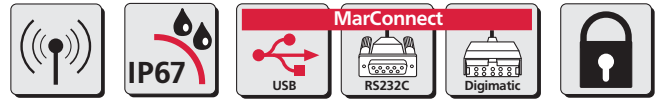

16 EWR-VS

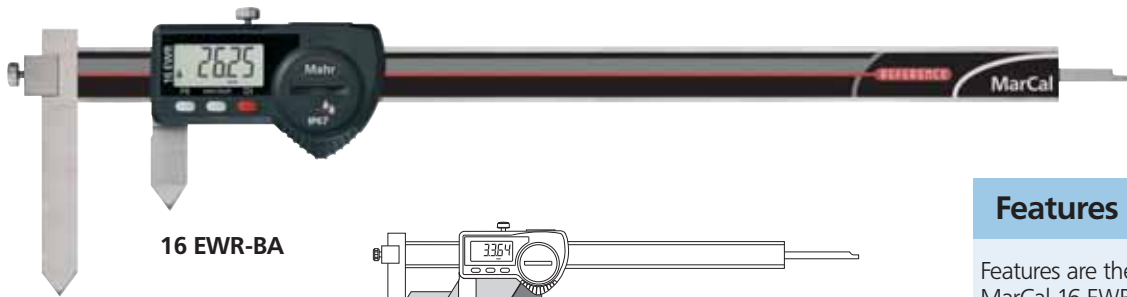
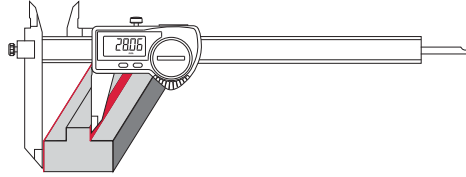

16 EWR-BA

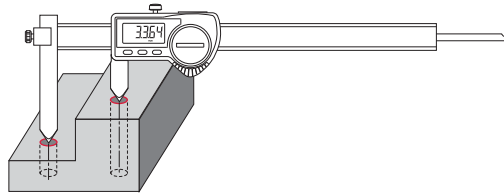

Features

Features are the same as the MarCal 16 EWR, please refer to Page 1-6, additional features can be found in the Technical Data.

Technical Data

	Measuring range		Resolution	Error limit G	Depth rod 	Order no.	Type
	mm	(inch)					
16 EWR-VS	0 - 200	(0 - 8")	0.01/ .0005"	0.03	●	4103083	Adjustable measuring jaws
16 EWR-BA	10 - 210	(.4 - 8.3")	0.01/ .0005"	0.03	—	4103084	Adjustable measuring jaws*

* to measure the distance between bores

16 EWR-VS

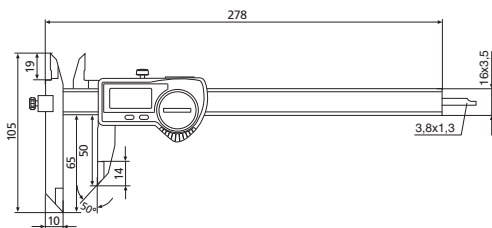

Dimensions

mm	a	b	c	d	e
200	10	40	16	235	16 x 3

16 EWR-BA

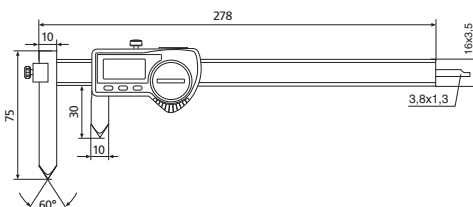

Accessories

Battery, Data Connection Cables see Page 1 - 6

Accessories for Data Processing see Chapter 11

Digital Caliper MarCal 16 EWR special design

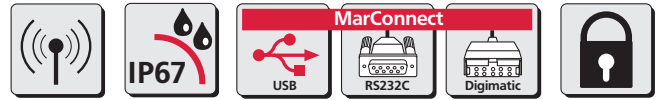

16 EWR-SA

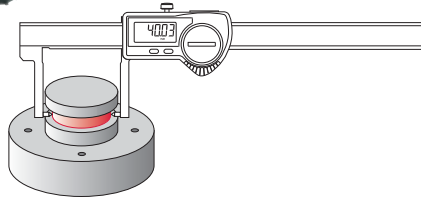

REFERENCE

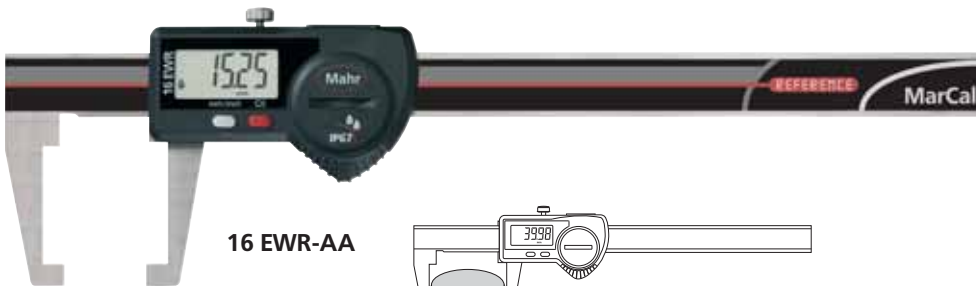

16 EWR-AA

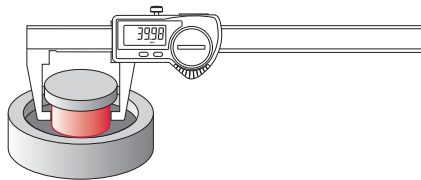

Features

Features are the same as the MarCal 16 EWR, please refer to Page 1-6, additional features can be found in the Technical Data.

Technical Data

	Measuring range		Resolution	Error limit G	Order no.	Type
	mm	(inch)				
16 EWR-SA	150	(6")	0.01/ .0005"	0.03	4103077	Inwardly angled anvils
16 EWR-AA	150	(6")	0.01/ .0005"	0.03	4103079	Inwardly angled measuring jaws

16 EWR-SA

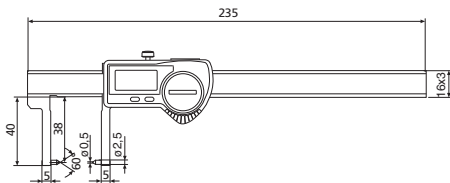

Dimensions

mm	a	b	c	d	e
150	10	40	16	235	16 x 3

16 EWR-AA

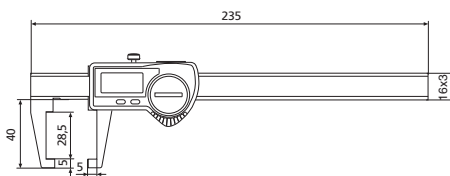

Accessories

Battery, Data Connection Cables see Page 1 - 6

Accessories for Data Processing see Chapter 11

Digital Caliper MarCal 16 EWR special design

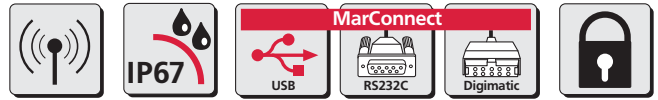

16 EWR-SI

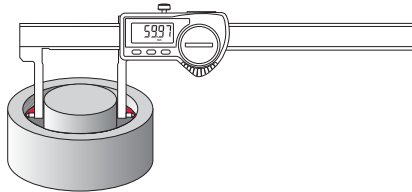

REFERENCE



16 EWR-AI

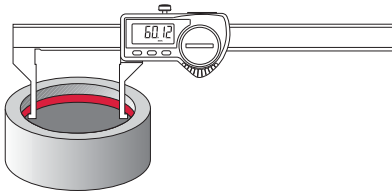

Features

Features are the same as the MarCal 16 EWR, please refer to Page 1-6, additional features can be found in the Technical Data.

Technical Data

	Measuring range		Resolution	Error limit G	Order no.	Type
	mm	(inch)				
16 EWR-SI	20 - 170	(.8 - 6.7")	0.01/ .0005"	0.03	4103078	Outwardly angled anvils
16 EWR-AI	10 - 160	(.4 - 6.3")	0.01/ .0005"	0.03	4103080	Outwardly angled measuring jaws

16 EWR-SI

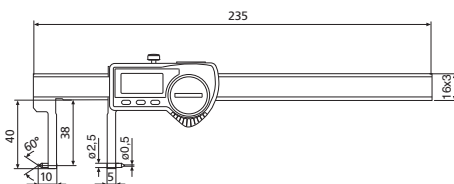

16 EWR-AI

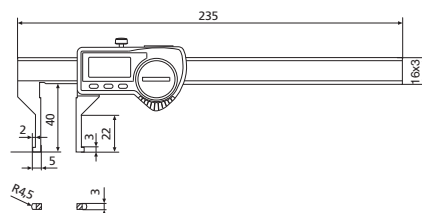

Accessories

Battery, Data Connection Cables see Page 1 - 6

Accessories for Data Processing see Chapter 11

Digital Caliper MarCal 16 EWR special design

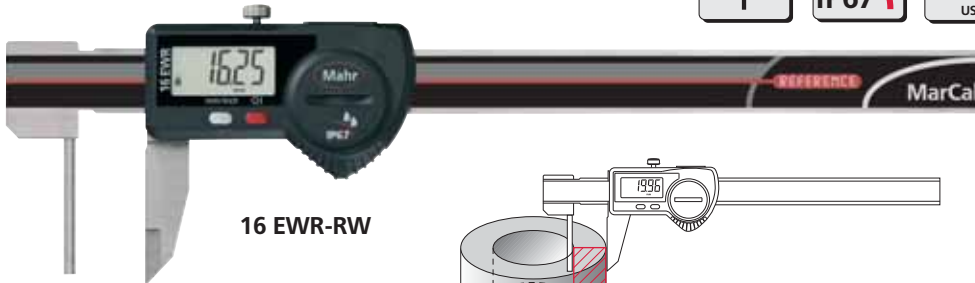
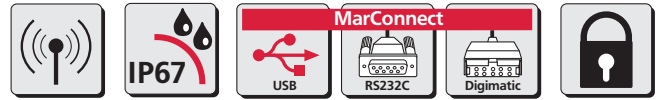

16 EWR-RW

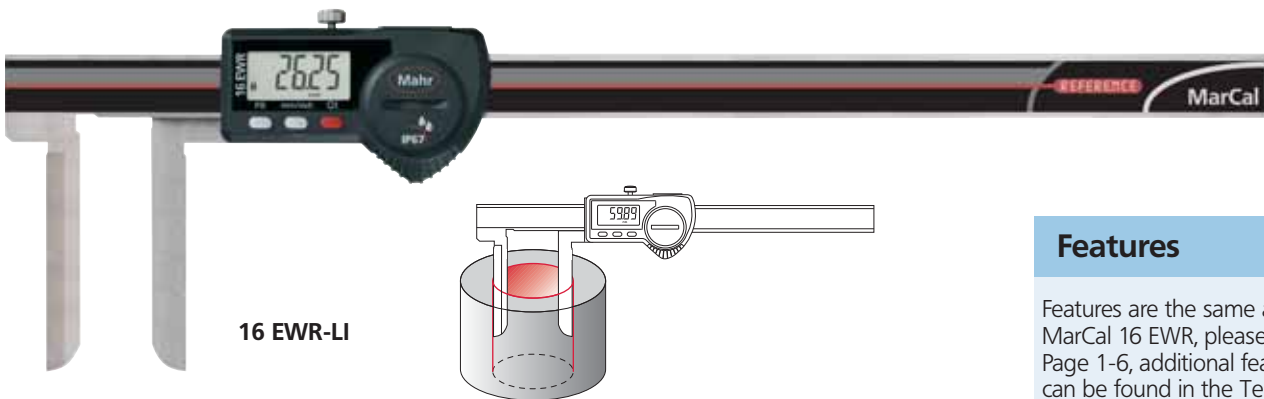

16 EWR-LI

Features

Features are the same as the MarCal 16 EWR, please refer to Page 1-6, additional features can be found in the Technical Data.

Technical Data

	Measuring range		Resolution	Error limit G	Order no.	Type
	mm	(inch)				
16 EWR-RW	0 - 150	(0 - 6")	0.01/ .0005"	0.05	4103081	Wall thickness measuring caliper
16 EWR-LI	10 - 200	(.4 - 8")	0.01/ .0005"	0.05	4103085	with long narrow measuring jaws

16 EWR-RW

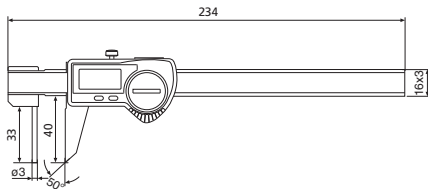

Dimensions

mm	a	b	c	d	e
150	10	40	16	235	16 x 3

16 EWR-LI

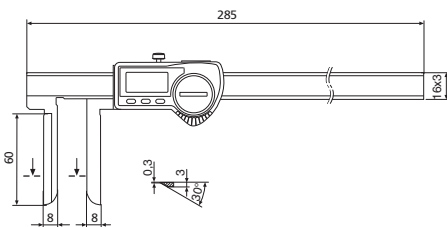

Accessories

Battery, Data Connection Cables see Page 1 - 6

Accessories for Data Processing see Chapter 11

Digital Caliper MarCal 18 EWR

REFERENCE

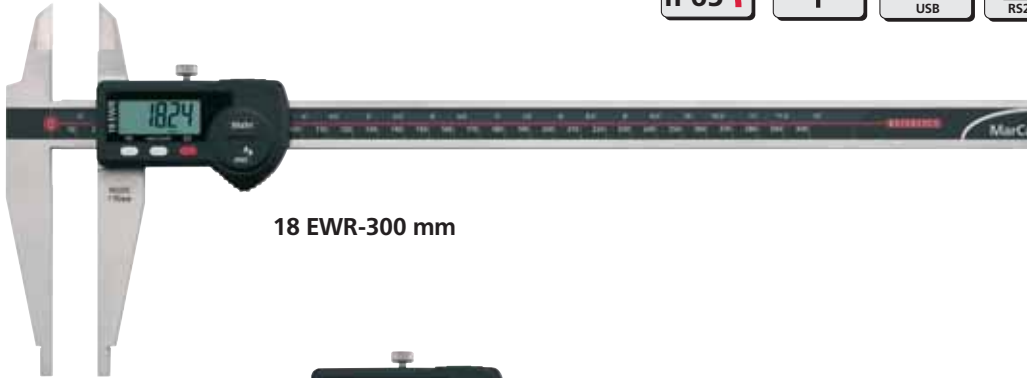

18 EWR-300 mm

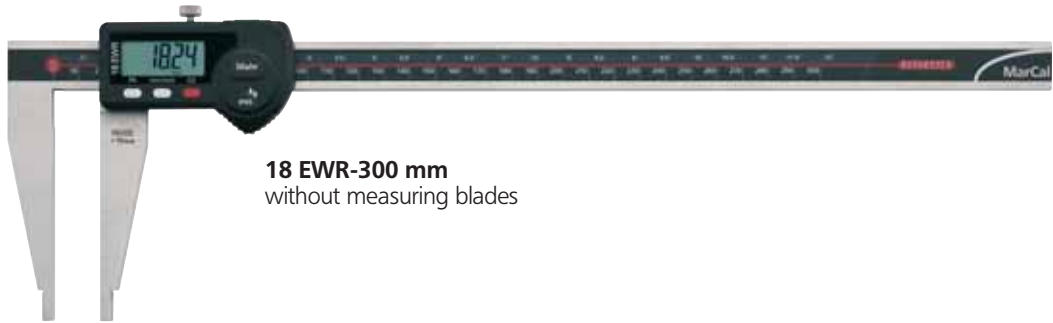

18 EWR-300 mm
without measuring blades

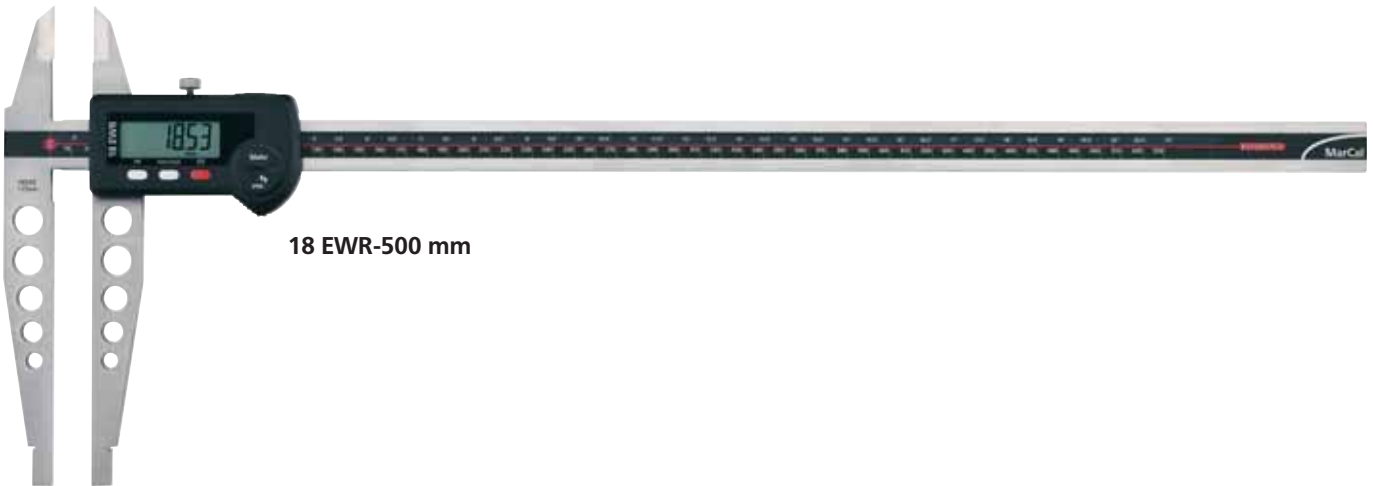

18 EWR-500 mm

Features

Functions:

- ON/OFF
- RESET (Set display to zero) mm/inch
- Reference-Lock/Unlock
- PRESET (for entering a numerical value) DATA (Data transmission via connection cable)
- Auto-ON/OFF

- Immediate measurement due to the Reference system
- Excellent resistance against dust, coolants and lubricants, protection class IP65
- MarConnect data output, choose alternatively: USB, OPTO RS232C or Digimatic

- Dirt wipers are integrated in the slide
- Life of the battery up to 3 years
- Max measuring speed 2.5 m/s (100"/s)
- High contrast LCD with 10 mm (only 300 mm) and 12.5 mm high digits
- Slide and beam made of

- hardened stainless steel
- Rounded measuring blades for inside measurement
- Locking screw
- Supplied with: Case, battery, operating instructions

Digital Caliper MarCal 18 EWR with measuring blades for outside measurement

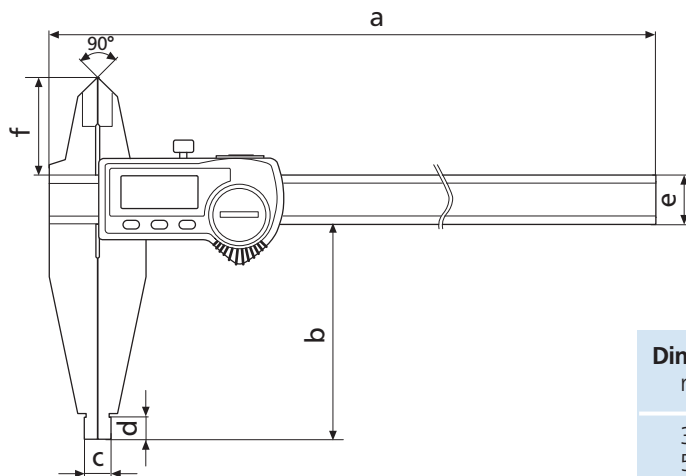

Dimensions

mm	a	b	c	d	e	f
300	410	90	10	10	20 x 4.5	40
500	650	150	20	20	25 x 5.5	55
750	905	150	20	20	25 x 5.5	55
1000	1165	150	20	20	30 x 6.5	60

Technical Data

Measuring range		Resolution	Error limit G	Weight	Order no. with meas. blades	Weight	Order no. without meas. blades
mm	(inch)	mm / inch	mm	kg		kg	
300	(12")	0.01 / .0005"	0.03	0.45	4112704	0.44	4112705
500	(20")	0.01 / .0005"	0.04	1.10	4112712	1.00	4112713
750	(30")	0.01 / .0005"	0.05	1.35	4112714	1.28	4112715
1000	(40")	0.01 / .0005"	0.06	2.20	4112716	2.10	4112717

Accessories

	Order no.
Battery 3V, Type CR 2032	4102520
Data Connection Cable USB (2 m)	16 EXu 4102357
Data Connection Cable Opto RS232C (2 m), with SUB-D jack 9-pin	16 EXr 4102410
Data Connection Cable Digimatic (2 m), Flat plug 10-pin	16 EXd 4102411

Accessories for Data Processing see Chapter 11

Digital Caliper MarCal 18 ESA lightweight construction



Features

Functions:

ON/OFF
 RESET (Zero setting)
 mm/inch
 HOLD (storage of measured values)
 DATA (Data transmission)

- Dirt wipers are integrated in the slide
- Max measuring speed 1.5 m/sec (60"/sec)
- Data output: Opto RS232C (only 300 mm version)
- High contrast Liquid Crystal Display with 6 mm or 10.5 mm high digits
- To reduce the overall weight the slide and beam are made from aluminum and are coated with a hard anodized surface coating (1100HV)
- Measuring faces are made of hardened stainless steel
- Prisma guide ways for a more smooth and even movement
- Measuring blades for outside measurement
- Rounded measuring faces for inside measurement
- Locking screw
- Supplied with: Case

Technical Data

Measuring range		Resolution	Error limit G		Weight	Order no.
mm	(inch)	mm / inch	mm / inch		kg	
300	(12")	0.01 / .0005"	0.03 / .001"	•	0.50	4112620
500	(20")	0.01 / .0005"	0.03 / .001"	—	1.40	4112621
800	(32")	0.01 / .0005"	0.07 / .0025"	—	1.60	4112622
1000	(40")	0.01 / .0005"	0.08 / .0032"	—	1.80	4112623

Dimensions

mm	a	b	c	d	e	f	g	h	i
300	450	33	90	24.5	10	10	25	4.5	17
500	726	42	150	33.5	15	20	31.9	6	29
800	1026	42	150	33.5	15	20	31.9	6	29
1000	1226	42	150	33.5	15	20	31.9	6	29

Accessories

	Order no.
Battery 3V, Type CR 2032	4102520
Data Connection Cable Opto RS232C (2 m), with SUB-D jack 9-pin	16 ESv 4102510
Accessories for Data Processing see Chapter 11	

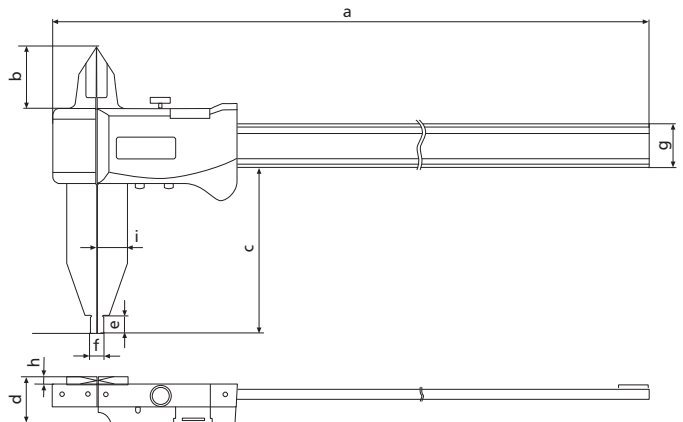

Caliper MarCal 18 NA lightweight construction



Features

- To reduce the overall weight the slide and beam are made from aluminum and are coated with a hard anodized surface coating (1100HV)
- Measuring faces are made of hardened stainless steel
- Prisma guide ways for a more smooth and even movement
- Measuring blades for outside measurement
- Rounded measuring faces for inside measurement
- Locking screw
- Supplied with: Case, over 1500 mm supplied in a cardboard box

Technical Data

Measuring range mm	Readings		Error limit <i>G</i> mm	Weight kg	Order no.
	upper mm	lower mm			
300	0.02	0.02	0.03	0.50	4112300
500	0.02	0.02	0.03	1.40	4112301
1000	0.02	0.02	0.08	1.75	4112303
800	0.02	0.02	0.07	1.60	4112302
1500	0.05	0.05	0.16	2.10	4112304
2000	0.05	0.05	0.16	2.50	4112305

Dimensions

mm	a	b	c	d	e	f	g	h	i
300	450	33	90	17.5	10	10	25	4.5	17
500	726	42	150	20.7	15	20	31.9	6	29
800	1026	42	150	20.7	15	20	31.9	6	29
1000	1226	42	150	20.7	15	20	31.9	6	29
1500	1760	85	200	25	15	30	48.1	6	40
2000	2260	85	200	25	15	30	48.1	6	40

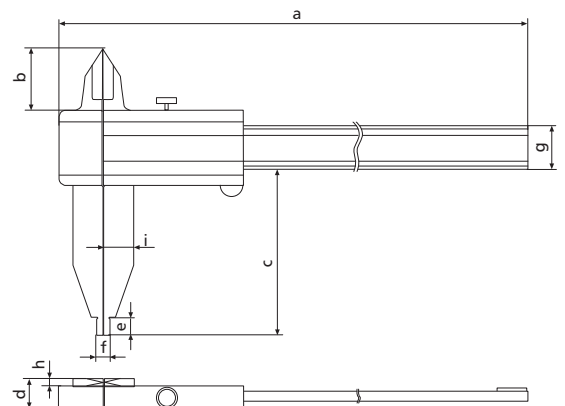

Vernier Caliper MarCal 18 N

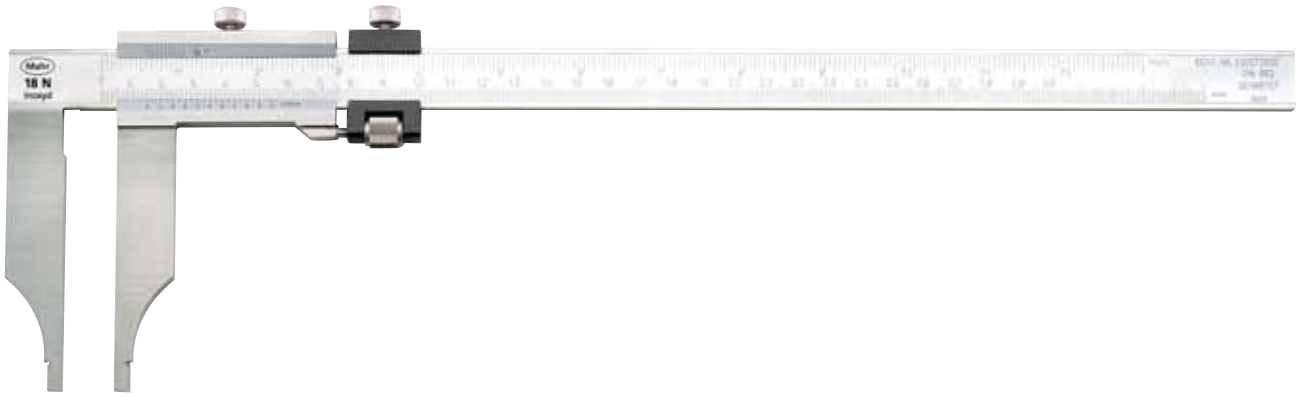

Features

- Vernier and main scale have a satin chrome finish for glare free reading
- Slide and beam made of hardened stainless steel
- Raised guide ways for the protection of the scale
- Rounded measuring faces for inside measurement
- Locking screw
- Supplied with: up to 1000 mm delivered with a case, over 1000 mm individually packed

Technical Data

Measuring range		Resolution		Error limit G		Order no.	Order no.
mm	(inch)	upper	lower	mm		without fine adjustment	with fine adjustment
200		0.02 mm	0.02 mm	0.05		4112200	
300		0.02 mm	0.02 mm	0.05		4112201	4112220
300	(12")	.001"	0.02 mm	0.05			4112230
500		0.02 mm	0.02 mm	0.06			4112221
500	(20")	.001"	0.02 mm	0.06			4112231
500		0.05 mm	0.05 mm	0.07	●	4112210	
800		0.02 mm	0.02 mm	0.08			4112222
800	(32")	.001"	0.02 mm	0.08			4112232
800		0.05 mm	0.05 mm	0.10	●	4112211	
1000		0.02 mm	0.02 mm	0.08			4112223
1000	(40")	.001"	0.02 mm	0.08			4112233
1000		0.05 mm	0.05 mm	0.12	●	4112212	
1500		0.02 mm	0.02 mm	0.10			4112224
1500	(60")	.001"	0.02 mm	0.10			4112234
1500		0.05 mm	0.05 mm	0.18	●	4112213	
2000		0.02 mm	0.02 mm	0.12			4112225
2000	(80")	.001"	0.02 mm	0.12			4112235
2000		0.05 mm	0.05 mm	0.22	●	4112214	

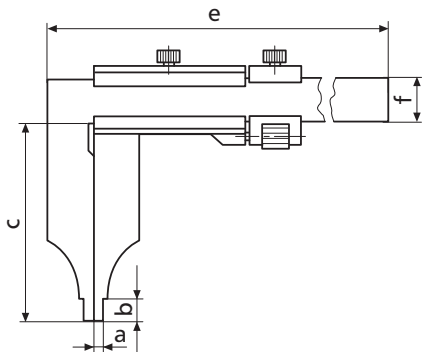

Dimensions

mm		a	b	c	e	f
18 N	200 mm	5	10	80	310	20 x 5
	300 mm	5	10	90	410	20 x 5
	500 mm	10	19	150	675	25 x 6
	800 mm	10	19	150	985	30 x 7
	1000 mm	10	19	150	1185	30 x 7
	1500 mm	15	19	200	1760	40 x 8
	2000 mm	15	19	200	2270	45 x 10

Vernier Caliper MarCal 18 DN with measuring blades for outside measurement

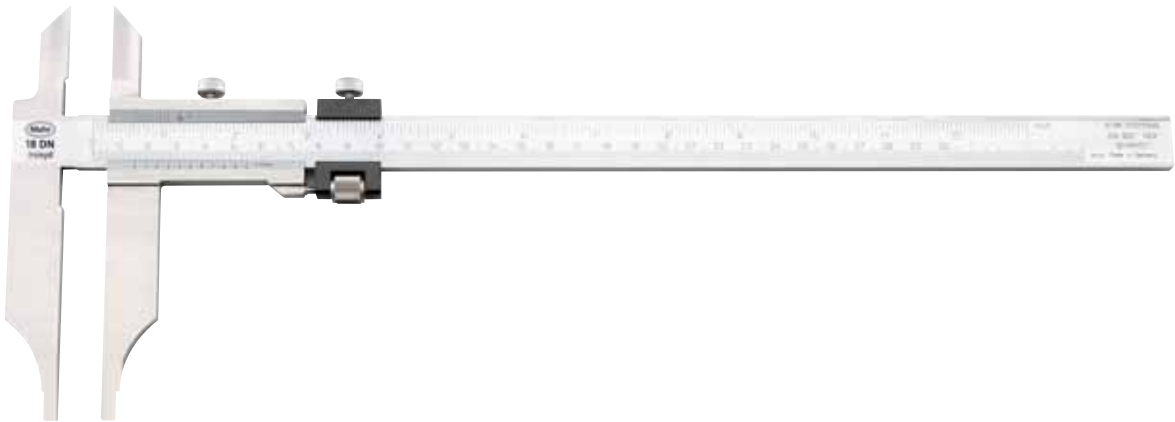

Features

- Vernier and main scale have a satin chrome finish for glare free reading
- Slide and beam made of hardened stainless steel
- Rounded measuring faces for inside measurement
- Supplied with: up to 1000 mm delivered with a case, over 1000 mm individually packed
- Raised guide ways for the protection of the scale
- Locking screw

Technical Data

Measuring range mm	Resolution		Error limit G		Order no. without fine adjustment	Order no. with fine adjustment
	upper	lower	mm	DIN 862		
200	0.05 mm	0.05 mm	0.05	●	4113200	
200	0.02 mm	0.02 mm	0.05			4113300
300	0.05 mm	0.05 mm	0.05	●	4113201	
300	0.02 mm	0.02 mm	0.05			4113301
500	0.05 mm	0.05 mm	0.07	●	4113202	
500	0.02 mm	0.02 mm	0.06			4113302
800	0.05 mm	0.05 mm	0.10	●	4113203	
800	0.02 mm	0.02 mm	0.08			4113303
1000	0.05 mm	0.05 mm	0.12	●	4113204	
1000	0.02 mm	0.02 mm	0.08			4113304
1500	0.05 mm	0.05 mm	0.18	●	4113205	
2000	0.05 mm	0.05 mm	0.22	●	4113206	

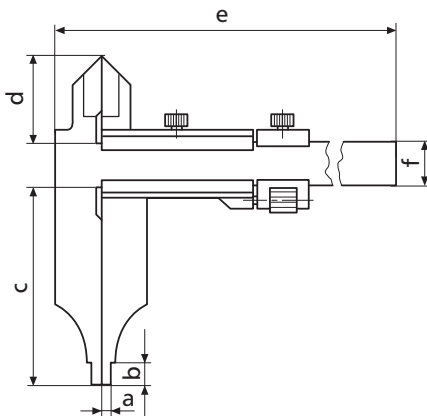

Dimensions

mm		a	b	c	d	e	f
18 DN	200 mm	5	10	80	40	310	20 x 5
	300 mm	5	10	90	40	410	20 x 5
	500 mm	10	19	150	60	675	25 x 6
	800 mm	10	19	150	65	985	30 x 7
	1000 mm	10	19	150	67	1185	30 x 7
	1500 mm	15	19	200	86	1760	40 x 8
	2000 mm	25	19	200	96	2270	45 x 10

Digital Depth Gage MarCal 30 EWR according to protection class IP67

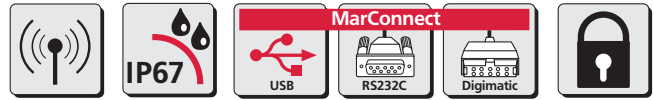

REFERENCE

Merkmale

Functions:

ON/OFF
 RESET (Set display to zero)
 mm/inch
 PRESET (enter a numerical value)
 Reference-Lock/Unlock
 Auto-ON/OFF

- Immediate measurement due to the Reference system
- Excellent resistance against dust, coolants and lubricants, protection class IP67
- MarConnect data output, choose alternatively: USB, OPTO RS232C or Digimatic

- Dirt wipers are integrated in the slide
- Life of the battery up to 3 years
- Max measuring speed 2.5 m/s (100"/s)
- High contrast LCD with 8.5 mm high digits
- Lapped guide way

- Beam and cross beam are made of hardened stainless steel
- Locking screw
- Supplied with: Case, battery, operating instructions

Technical Data

Measuring range		Resolution	Error limit G	Order no.
mm	(inch)	mm/inch	mm/inch	
150	(6")	0.01 / .0005"	0.03/ .001"	4126700
300	(12")	0.01 / .0005"	0.04/ .0015"	4126701
500	(20")	0.01 / .0005"	0.05/ .0020"	4126702

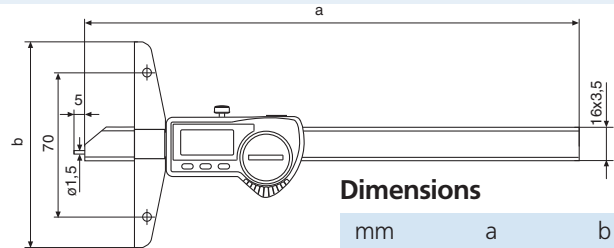

Dimensions

mm	a	b
150	234	100
300	384	150
500	584	150

Depth measurement

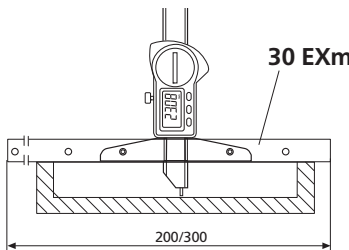

Distance measurement

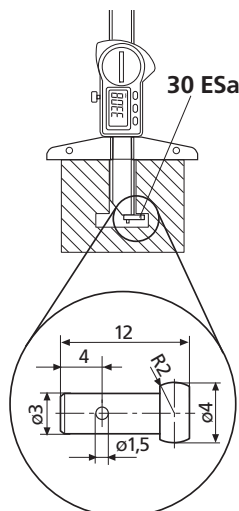

Accessories

	Order no.
Battery 3V, Type CR 2032	4102520
Data Connection Cable USB (2 m)	16 EXu 4102357
Data Connection Cable Opto RS232C (2 m), with SUB-D jack 9-pin	16 EXr 4102410
Data Connection Cable Digimatic (2 m), Flat plug 10-pin	16 EXd 4102411
Cross Beam Extension 200 mm	30 EXm 4126511
300 mm	30 EXm 4126510
Anvil for distance measurement to be fixed to the measuring pin	30 ESa 4125611

Accessories for Data Processing see Chapter 11

Digital Depth Gage MarCal 30 ER



REFERENCE

Features

Functions:

- ON/OFF
- RESET (Set display to zero)
- mm/inch
- PRESET (enter a numerical value)
- Reference-Lock/Unlock
- Auto-ON/OFF
- Immediate measurement due to the Reference system

- MarConnect data output, choose alternatively: USB, OPTO RS232C or Digimatic
- Dirt wipers are integrated in the slide
- Life of the battery up to 3 years
- Max measuring speed 2.5 m/s (100"/s)

- High contrast LCD with 8.5 mm high digits
- Lapped guide way
- Beam and cross beam are made of hardened stainless steel
- Locking screw

- Supplied with: Case, battery, operating instructions

Technical Data

Measuring range		Resolution	Error limit	Order no.
mm	(inch)	mm/inch	G	
150	(6")	0.01 / .0005"	0.03	4126514
300	(12")	0.01 / .0005"	0.04	4126515
500	(20")	0.01 / .0005"	0.05	4126516

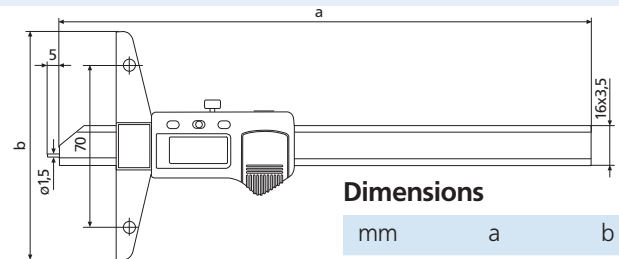

Dimensions

mm	a	b
150	234	100
300	384	150
500	584	150

Depth measurement

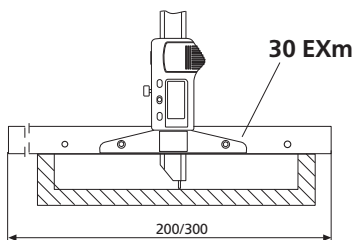

Distance measurement

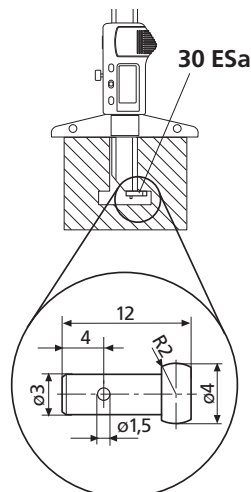

Accessories

	Order no.
Battery 3V, Type CR 2032	4102520
Data Connection Cable USB (2 m)	16 EXu 4102357
Data Connection Cable Opto RS232C (2 m), with SUB-D jack 9-pin	16 EXr 4102410
Data Connection Cable Digimatic (2 m), Flat plug 10-pin	16 EXd 4102411
Cross Beam Extension 200 mm	30 EXm 4126511
300 mm	30 EXm 4126510
Anvil for distance measurement to be fixed to the measuring pin	30 ESa 4125611

Accessories for Data Processing see Chapter 11

Digital Depth Gage MarCal 30 EWN



Version A



Version B

REFERENCE

Applications

- Ideal for measuring the width of grooves and distances between grooves

Features

Functions:

- ON/OFF
- RESET (Set display to zero)
- mm/inch
- PRESET (enter a numerical value)
- Reference-Lock/Unlock
- Auto-ON/OFF

- Immediate measurement due to the Reference system
- Excellent resistance against dust, coolants and lubricants, protection class IP67
- MarConnect data output, choose alternatively: USB, OPTO RS232C or Digimatic

- Dirt wipers are integrated in the slide
- Life of the battery up to 3 years
- Max measuring speed 2.5 m/s (100"/s)
- High contrast LCD with 8.5 mm high digits

- Beam and cross beam are made of hardened stainless steel
- Locking screw
- Supplied with: Case, battery, operating instructions. Version A: Anvils 30 ENT (1 mm), 902 and 903

Technical Data

Measuring range		Length of cross beam	Resolution	Error limit G	Version	Order no.
mm	(inch)	mm	mm / inch	mm / inch		
100	(4")	85	0.01 / .0005"	0.03/ .001"	A	4126512
200	(8")	100	0.01 / .0005"	0.03/ .001"	B	4126517
300	(12")	150	0.01 / .0005"	0.03/ .001"	B	4126518

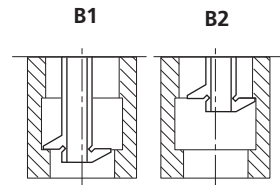
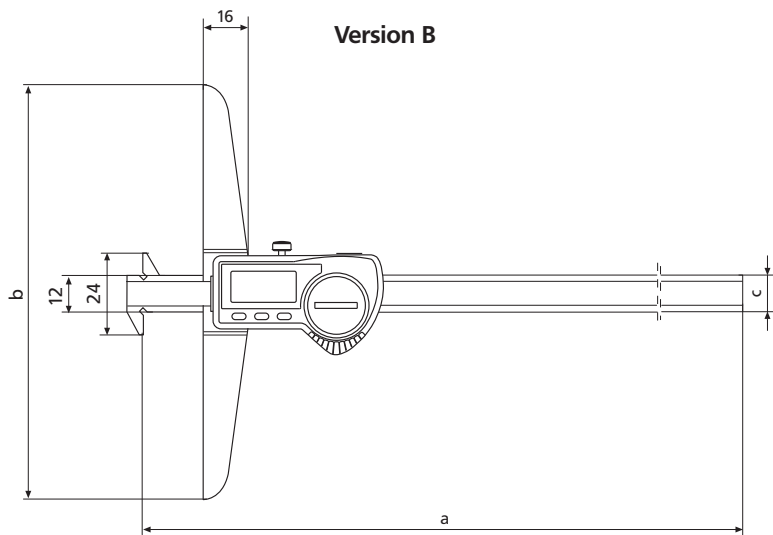
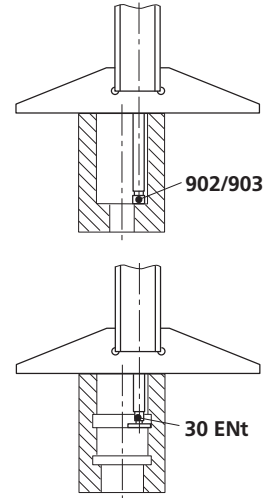
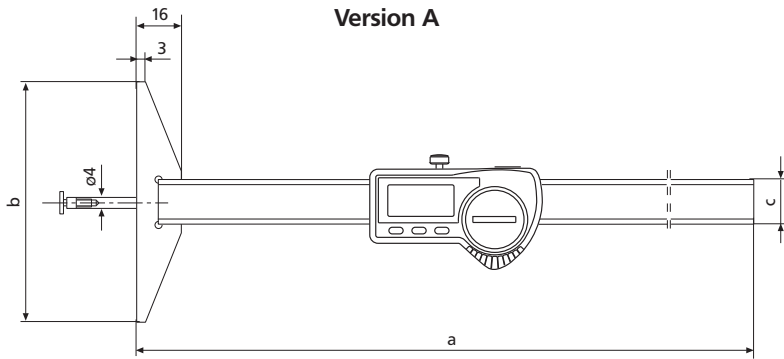

Dimensions

mm	a	b	c
100	268	85 x 8.5	16 x 3
200	281	100 x 8.7	11.5 x 3.6
300	381	150 x 8.7	11.5 x 3.6

Accessories

	Order no.
Battery 3V, Type CR 2032	4102520
Data Connection Cable USB (2 m)	16 EXu 4102357
Data Connection Cable Opto RS232C (2 m), with SUB-D jack 9-pin	16 EXr 4102410
Data Connection Cable Digimatic (2 m), Flat plug 10-pin	16 EXd 4102411
Disc Type Anvil 0.5 mm thick, hardened	30 ENT 4126310
Disc Type Anvil 1 mm thick, hardened	30 ENT 4882022

Accessories for Data Processing see Chapter 11

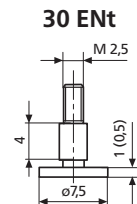
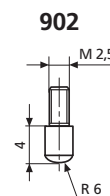
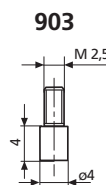

Depth Gages MarCal 30 N / 30 NH / 30 ND

DIN 862

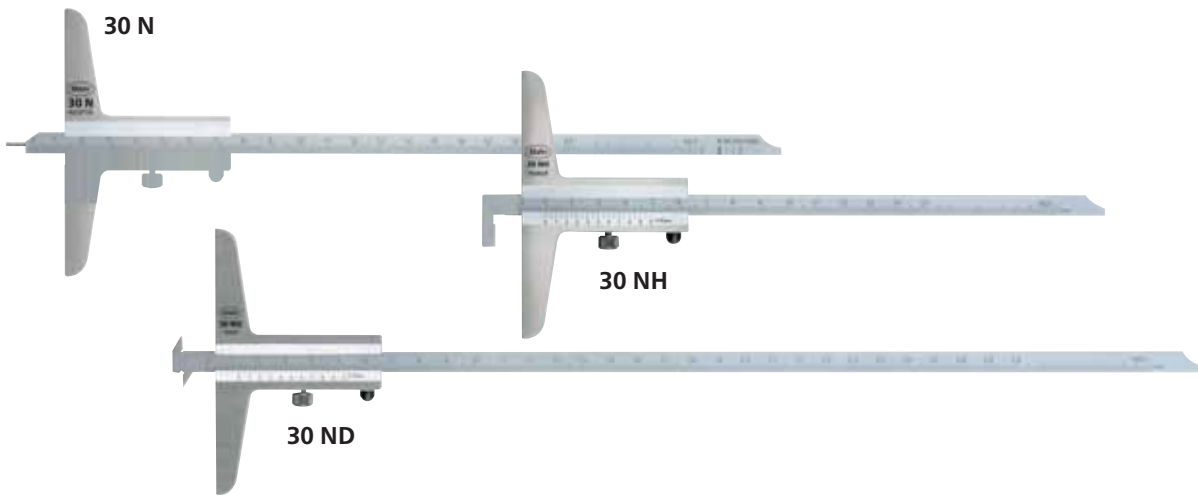

Features

- Vernier and main scale have a satin chrome finish for glare free reading
- Slide, beam and cross beam are made of hardened stainless steel
- Raised guide ways for the protection of the scale
- Locking screw
- Supplied with: Case

Technical Data

Measuring range mm	Vernier scale mm	Error limit G mm	Order no. 30 N with hardened measuring pin	Order no. 30 NH with hook	Order no. 30 ND with twin hook
80	0.05	0.05	4127200		
150	0.05	0.05	4127300	4127350	
200	0.05	0.05	4127301	4127351	4127410
300	0.05	0.05	4127201	4127352	4127411
500	0.05	0.07	4127202	4127353	

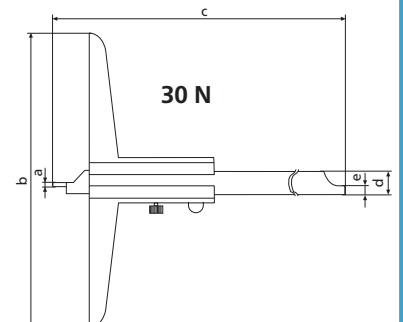
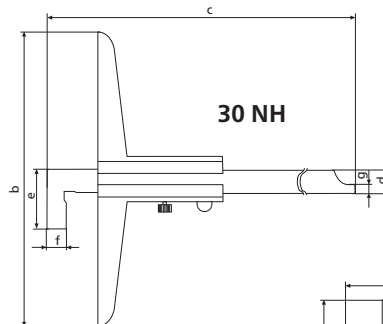
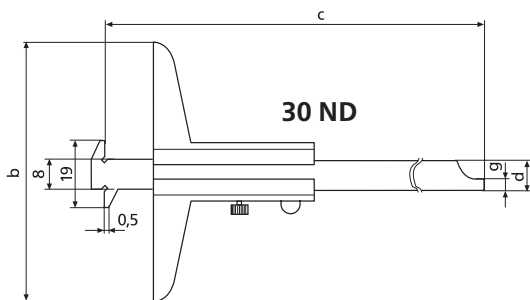

Dimensions

mm	dia. a	b	c	d	e	f	g
80 mm	1	50	140	8 x 3	-	-	-
150 mm	1.5	100	235	8 x 3	20	5	3.5
200 mm	1.5	100	285	8 x 3	20	5	3.5
300 mm	2.0	150	390	12 x 4	28	10	4
500 mm	2.0	150	590	12 x 4	28	10	4

Digital Linear Machine Gage MarCal 31 EW



REFERENCE

Application

- For measuring travel on a machine (e.g. on an upright drilling machine, milling machine)

Features

Funktionen:

ON/OFF
 RESET (Set display to zero)
 mm/inch
 Reference-Lock/Unlock
 PRESET (for entering a numerical value)
 DATA (Data transmission via connection cable)
 Auto-ON/OFF

- Immediate measurement due to the Reference system
- Excellent resistance against dust, coolants and lubricants, protection class IP54

- MarConnect data output, choose alternatively:
 USB
 OPTO RS232C
 Digimatic
- Dirt wipers are integrated in the slide
- Life of the battery up to 3 years

- Max measuring speed 2,5 m/s (100"/s)
- High contrast LCD with 10 mm (only 300 mm) and 12.5 mm high digits
- Supplied with:
 Battery,
 operating instructions

Technical Data

Measuring range		Resolution mm / inch	Error limit G µm	Order no.
mm	(inch)			
150	(6")	0,01 / .0005"	30	4104100
200	(8")	0,01 / .0005"	30	4104101
300	(12")	0,01 / .0005"	40	4104102
600	(24")	0,01 / .0005"	50	4104103

Dimensions

mm	a	b	c
150	185	282	398
200	235	332	348
300	335	432	448
600	665	762	778

Accessories

	Order no.
Battery 3V, Type CR 2032	4102520
Data Connection Cable USB 800 EWu	4305121
Data Connection Cable Opto RS232 800 EWr	4305122

Accessories for Data Processing see Chapter 11

